

# Installing the CMix card

## CMix Card Guide

The CMix card, derived from the FLOOR card, has a modified firmware that allows it to manage:

- 1 mixed circuit
- 1 direct drive circuit, unmixed (High Temperature, or HT)

The commands to activate the two circuits are not transmitted via MODBUS but via 2 clean contacts (see Fig.1).

In this way the CMix card allows the Kita heat pump to interface with traditional systems with a clean contact timer-thermostat.

### HT circuit:

When the HT contact closes, the system checks if the puffer water is hot enough (heating) or cold (chiller) to activate the relative circulator.

### Mixed circuit:

When the CMix contact closes, the system checks whether the water in the puffer is sufficiently warm (heating) or cold (cooling) and activates the mixing circuit. If the puffer temperature is too hot or too cold, the board commands the mixing valve to maintain the desired flow temperature.

Relay outputs 1 to 6 can be associated with the operation of the mixed circuit if desired. For example you can control the control valves or any relaunching circulators.

To associate the relays, see Configuring the CMix card chapter.

## Notes on the preparation of the system

MODBUS cable: Templari HCC cable (similar Belden 3105A 2x22AWG shielded)

Power cable: 2x1 mmq

Power supply: HCC POW 24Vdc, 2.5A

For more information on installation, refer to the HCC manual received with the HCC Touch panel.

### Modbus connection

#### ⚠ WARNING!

We recommend using the HCC CABLE data cable

The connection between the CMix board and the Kita Touch panel can be made via an additional BMS board (figure 2) or via the P-LAN connector (figure 3). In this last case it is mandatory to connect the ID9 connector to GND, as in figure 3.

**The connections must respect the indications of the figures, otherwise the system will not work.**

**Connect the G (Ground) pole of the HCC Connect cable of the Touch HCC Panel to the shield of the Modbus data network.**

**Connect the ground terminal of the power supply to the shield of**

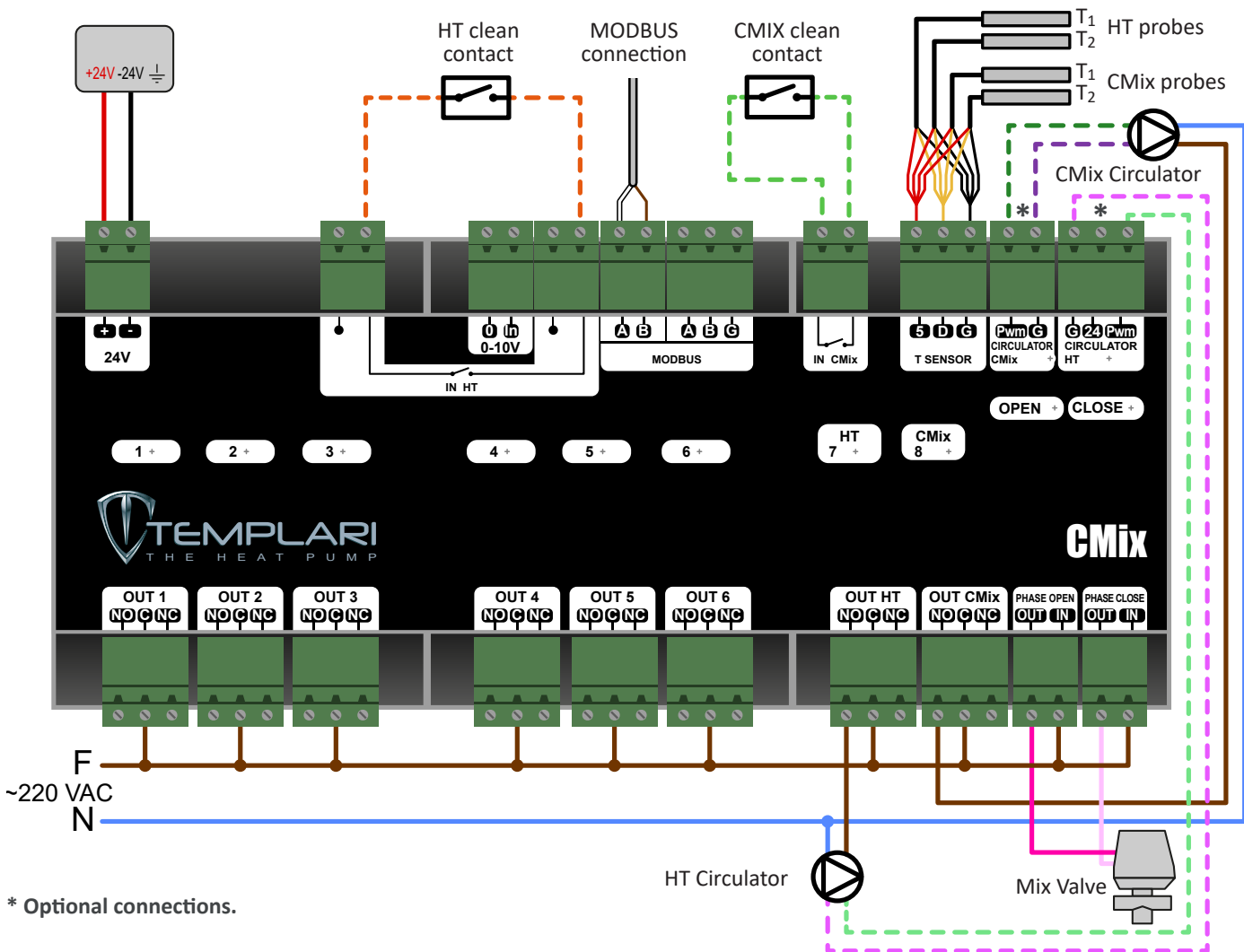

\* Optional connections.

Figura 1

the Modbus data network.

The shields of the various cable sections, between the various devices (HCC ROOM sensor and HCC FLOOR board), must be connected in series and NOT inserted in the G pole of each device, as in Fig3.

The CMix board default address for the MODBUS network is 222. For all the details on the wiring, on change the address address to the board, for the connection of the MODBUS network to the KITA heat pump, refer to chapter I of the HCC manual supplied with the HCC Touch panel.

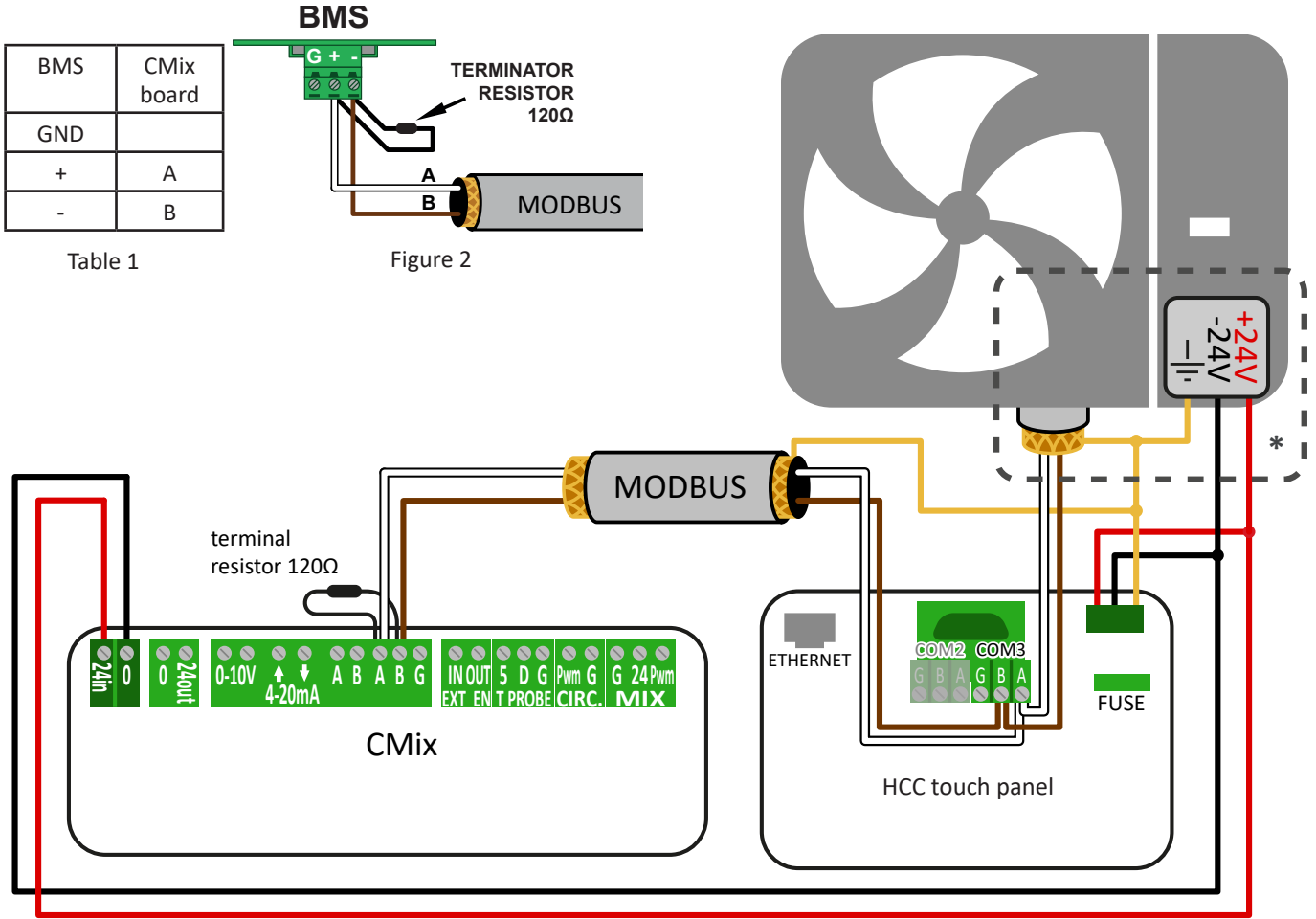

Figure 3

## Configuring the CMix card

In order to use the CMix card it is necessary to have an HCC Touch panel, sold separately. The card must be installed and enabled.

Once the card is installed it is necessary to inform the HCC Touch panel that the CMix is ready. To do this, access the Panel builder screen. To access the screen, refer to the HCC manual.

This screen is password protected and only competent personnel are authorized to access it.

### **⚠ WARNING!**

Every time a peripheral is installed, the installation must be notified to the system by switching on the button on this screen. If not, the system will not work properly and could lead to damage to the system.

## Builder screen

**CMix 11** **MODBUS CMix address.** Here you can see the address used in the MODBUS network to communicate with CMix cards. Touching the dot associated with the card will open the CMix settings screen. An unlit button indicates that a CMix card with that address has not been installed.

## CMix setting screen

- MODBUS address of the card.
- CMix card setpoint.
- Notification of successful installation.
- Maximum and minimum temperatures allowed when the board works in heating mode.
- Maximum and minimum temperatures allowed when the board works in chiller mode.
- Relays associated in heating mode. When the board is working during heating mode, it closes the indicated relays.

- Relays associated in heating mode. When the board is working during chiller mode, it closes the indicated relays.
- Exit the screen without saving.
- Identification of the observed card.
- Exit the screen and save the settings on the screen.

## Enabling the CMix board

An installed card is not yet enabled for working. To enable the CMix board go to the Advanced screen. To access the Advanced screen, refer to the HCC manual. This screen is password protected and only competent personnel are authorized to access it.

Touching the square associated with the installed board, the CMix will be enabled and can therefore work regularly.

## CMix board overview

To view how a CMix card works, go to the HCC Touch Panel Environments list screen. To access the Environments list screen, refer to the HCC manual.

Then touch the CMix writing at the bottom. This will take you to the CMix List screen.



On this screen you can see a list of the installed CMix boards. Those with the darkest color are installed and enabled. Touching one you get to the Overview screen of the relevant CMix card.

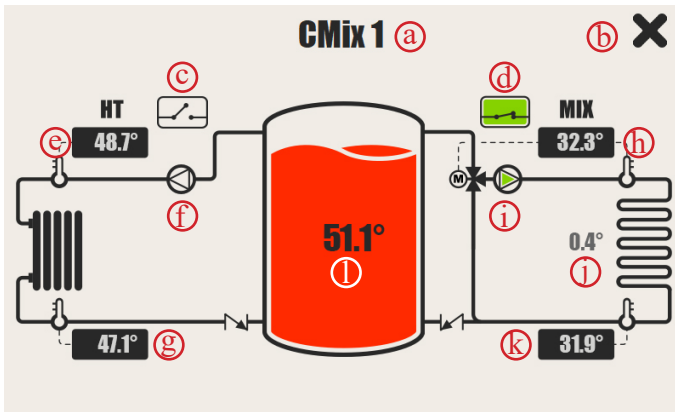

- a. Identification of the card observed.
- b. Exit from the screen.
- c. High Temperature Relay. If the relay is closed then this icon turns on.
- d. Mixing Relay. If the relay is closed then this icon turns on.
- e. Outlet temperature of the High Temperature circuit.
- f. High Temperature circuit Circulator. If the circulator is active then this icon turns on.
- g. Inlet temperature of the High Temperature circuit.
- h. Outlet temperature of the straight-line Mixing.
- i. Mixing Circulator. If the circulator is active then the icon turns on.
- j. Delta of the circuit Mixing. It is the difference between the delivery temperature (h) and the return temperature (k).
- k. Inlet temperature of the Mixing circuit.
- l. Puffer temperature. The color of the puffer changes according to the type of work. In heating mode it is orange, in cooling mode it is blue.