





Installation and maintenance manual



Summary

1	Introduction	6
1.1	General warnings.....	6
1.2	Recommended equipment	6
1.3	Description of the series	6
2	Read carefully before use	7
2.1	Important information.....	7
2.2	Important information regarding the refrigerant used	7
2.3	Proper use	8
2.4	Rules and legal provisions.....	8
2.5	Energy saving.....	8
3	Intended use of the heat pump.....	8
3.1	Field of work and safety devices	8
3.2	Allowed operative zone	9
3.2.1	KITA with Twin Rotary	9
3.2.2	KITA with scroll vapour injection.....	9
3.3	Structure of the system with heat pump.....	9
3.4	Components KITA Line S - Line Si - Line Mi	9
3.5	Components KITA Line Mi Plus - Line Mi Plus Cold - L33	10
3.6	Components KITA L42, L66.....	10
3.7	Components KITA Li PLUS	11
3.8	Operation mode	11
4	Scope of supply	11
4.1	Main unit.....	11
4.2	Type name and serial number.....	11
4.3	Components scheme of heat pump KITA S/Si/Mi Templari® external unit	13
4.4	Component scheme of external unit of heat pump LINE KITA L Templari®	14
4.5	Components scheme of heat pump KITA Li Plus Templari® external unit	15
4.6	Components scheme of heat pump KITA S/Si/Mi/L Templari® internal unit	16
4.7	Components scheme of heat pump KITA Li Plus Templari® internal unit.....	17
5	Transport.....	18
6	Assembly and installation.....	18
6.1	Components supplied	18
6.2	External unit sizes.....	18
6.3	Free spaces to assembly the outdoor unit.....	20
6.4	Choice of the installation place	20
6.5	Outdoor unit assembly	21
6.6	Preparation of condensate drain.....	21
6.7	Alignment of the outdoor unit.....	22
6.8	Probe installation	22
7	Assembly and installation of the indoor unit.....	22
7.1	Sizes and components of the indoor unit.....	23
7.2	General information and choice of the place to instal the indoor unit.....	23

8	Connections of the refrigerant circuits	24
8.1	Installation requirements	24
8.2	Preparing for installation and installation of refrigerant pipes.....	24
8.3	Void procedure	25
9	Hydraulic connections	25
9.1	General information	25
9.2	Special components.....	25
9.3	Installation of the hydraulic part.....	26
9.4	Choice of the system diagram	26
9.5	Dyagram 1: heating and DHW  system with buffer	27
9.6	Dyagram 2: heating and DHW  system with buffer and boiler backup	28
9.7	Dyagram 3: heating and dhw “t” system with instant DHW  production plate exchanger kit	29
9.8	Dyagram 4: heating\cooling “t” system with air handling unit	30
9.9	Dyagram 5: heating\cooling and DHW  “T” system	31
10	Maintenance and cleaning.....	32
10.1	Cleaning of the battery	32
10.2	Cleaning of condensate drain.....	32
10.3	Cleaning of hydraulic system side	32
10.4	Cooling circuit maintenance.....	32
11	Electrical connection.....	32
11.1	General information	32
11.2	Laying operations	33
11.3	Power.....	33
11.4	Outside unit connection	34
11.5	Connection between indoor and outdoor unit.....	34
11.6	Connection of the remote panel	34
12	Terminal wiring.....	34
12.1	Indoor unit connectors wiring.....	34
12.2	Terminal wiring outdoor unit	35
12.3	Version 1: Terminal wiring for KITA with circulator and and Relay K2 only	36
12.4	Version 2: One relay for circulator management and one for DHW management with Templari - de pala 3-way valve	39
12.5	Version 3: One relay for circulator management, one relay for DHW management, one relay for additional integration	42
12.6	9 KW Kita auxiliary heating element	44
12.7	TSplit description.....	45
12.8	TSplit installation.....	48
12.9	230 V power supply connection, CONN 1	48
12.10	Description CONN 3 connection and AUX relay configuration.....	48
12.11	Connection CONN 5 and digital inputs description	49
12.12	HCC connection (CONN7).....	49
12.13	TSplit board description and antifreeze.....	49
12.14	Plant Aware Function	52
12.15	Wiring pLAN net - “multi-KITA”	53
13	Electronic board	54

13.1	Digital outputs.....	54
13.2	Digital inputs	54
13.3	Analog outputs.....	54
13.4	Analog inputs	54
13.5	Wiring diagram KITA S / S Plus mono-phase - Singola alimentazione	55
13.6	Wiring diagram KITA S 3Ph / S 3Ph Plus.....	56
13.7	Wiring diagram KITA Si / Si Cold / Si Plus / Si Plus Cold / Mi / Mi Cold / Mi Plus / Mi Plus Cold mono-phase	57
13.8	Wiring diagram KITA Si 3Ph / Si Cold 3Ph / Si Plus 3Ph / Si Plus Cold 3Ph /Mi 3Ph / Mi Cold 3Ph / Mi Plus 3Ph / Mi Plus Cold 3Ph / L33 / L42.....	58
13.9	Wiring diagram KITA L66 / L Cold / Li Plus	59
13.10	Internal wiring connection diagram	60
13.10.1	Circulation pump.....	60
13.10.2	Fan.....	60
13.10.3	4-way valve and carter resistance wiring	60
13.10.4	wiring probe	60
14	Start up	61
14.1	Preliminary checks.....	61
14.2	Test and start up	61
15	K-Touch Panel	63
15.1	Warnings	63
15.2	Notes on the plant preparation for K-Touch panel.....	63
15.3	Connecting to the Kita heat pump	64
15.4	System overview	64
16	HCC connection	64
16.1	Exploded view: PPlan connection (7a) or BMS connection (7b)	66
17	Control terminal	68
17.1	Fixing of the panel.....	68
17.2	Measures of unit command	68
17.3	Menu overview	69
17.4	Terminal buttons	70
17.5	Terminal display	70
17.6	Main menu	71
17.7	Menu ON-OFF.....	71
17.8	Menu SETPOINT	71
17.9	Menu Clock/time slots.....	72
17.10	Menu Inputs/Outputs.....	73
17.11	Menu alarm history	73
17.12	Menu board change.....	73
17.13	Menu assistance	73
18	Alarms.....	78
18.1	Alarms resolution	80
18.2	Notifications.....	81
19	Declaration of conformity.....	82

1 Introduction

This manual wants to give all the information necessary to the installation and the correct operation of the heat pump **KITA Templari®** and its startup for its whole life cycle. This document is divided in chapters, where you can find general information and operation mode.



This product contains fluorinated greenhouse gases covered by the Kyoto Protocol. Do not vent gases into the atmosphere.

1.1 General warnings

- The choice and the use of the unit to serve the conditioning system have to be made by a competent staff according to the current rules in place so to completely satisfy the requests of the system.
- The installation, the startup and the maintenance have to be made by a competent staff able to evaluate the possible presence of risk factors or malfunction of the machine.
- The unit is supplied complete with all the options and functions directly by the manufacturer, every manumission of the fridge part or of the software isn't allowed. Possible manumissions will make expire the operation of the machine and the responsibility of the manufacturer.
- Periodic inspections and a correct maintenance of the heat pump **KITA Templari®**, can avoid damages to the unit and possible costs for the repairs.
- **The warranty expires in case of installation out of specification.**
- Keep this manual with the necessary schemes in places easily accessible.
- In case of malfunction verify the error code on the control panel, if necessary contact the manufacturer and ask original spare parts.
- On the label of the heating pump **KITA Templari®** you can find all the information according to the current labeling rules, in particular you can find:
 - Power of the machine in voltage and frequency;
 - Thermal power in heating and cooling regimes;
 - Maximum power;
 - Level of sound power;
 - Refrigeratore used.

1.2 Recommended equipment

- Star and flat head screwdriver set;
- Wire cutter;
- Scissors;
- Wrenches or pipe wrenches set;
- Ladder;
- Hydraulic material for the wires seal;
- Electrical equipment for links;
- Protective gloves;
- Current clamp;

1.3 Description of the series

The series of the heating pump **KITA Templari®** shows splitted hydronic heat machines for the production of heating and cooling energy and for the production of domestic hot water with the best technologies in the market.

The heating pump **KITA Templari®** is a series of full-inverter machines having high performance and widely dimensioned components to favor the efficiency of the machine. Other detail is the implementation of the technology EVI (Enhanced Vapour Injection) in the models KITA L, L42 and L66, widening the work field and the heat pump power. The use of the gas R410A allows to reach high performances and low environmental impact. The presence of two electronic valves, inversion valve, pressure transducers and temperature probes ensure, through the software integrated as microprocessor in the electronic board, full functionality and reliability of the machine in the different regimes of operation. The control of the machine is made by a remote control permitting to monitor the operation of the machine and change the temperature set of the water produced and the operation mode (summer/winter).

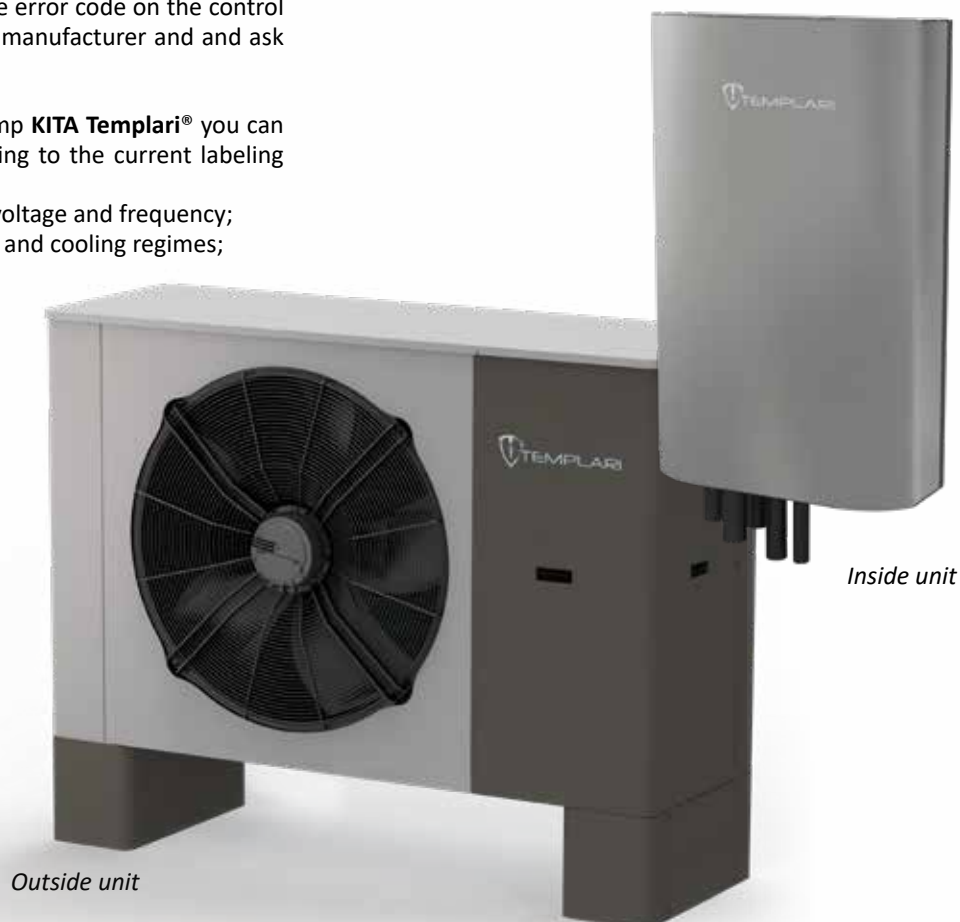

2 Read carefully before use

2.1 Important information

WARNINGS!

The exercise and the maintenance of the heating pump **KITA Templari®**, are subjects to the legal system of the countries where it is used. According to the quantity of the cooling fluid it is necessary to regularly check and note the sealing of the heat pump resorting to a qualified staff.

- During the transport it is possible to tilt the heating pump no more than 45° (in every direction).
- **The security for the transport has to be removed before the startup.**



- The aspiration and drain zone can't be reduced or covered.
- Respect the specific building regulation of the individual countries.
- Concerning the installation near the wall you have to consider the influences caused by factors in building physics. In the drain area of the fan there can't be windows or doors.
- With the installation near the wall the air flow in the aspiration and drain zone can increase deposits of impurities. The colder outside air has to exit so not to increase the heat loss of the heated rooms nearby.
- The dirt trap, not supplied but available on customer's demand, has to be assembly on the return pipes upstream of the heat pump.
- The installation in niches and courtyards isn't allowed, since the cold air accumulates on the ground and in case of prolonged operation it would be sucked back by the heat pump.
- The freezing limit can change according to the climatic region. Respect the current rules for the countries concerned.
- Respect the right-handed rotation camp: in case of wrong wiring the startup of the heat pump is thwarted. Heat pump programmer shows the relevant warnings (correct the wiring).
- The operation of the heat pump with too low system temperatures can cause its total stop. After prolonged power cut use the startup method described below.
- Regularly clean the dirt trap.
- Prior to opening the unit cut off power to all electrical circuits.
- The intervention on the heat pump can just be made by service authorized and competent staff.

2.2 Important information regarding the refrigerant used

This product contains fluorinated greenhouse gases covered by the Kyoto Protocol. Do not vent gases into the atmosphere.

Refrigerant type: R410A

GWP(1) value: 1975

(1) GWP = global warming potential

Please fill in with indelible ink,

- ① the factory refrigerant charge of the product,
- ② the additional refrigerant amount charged in the field and
- ①+② the total refrigerant charge

on the fluorinated greenhouse gases label supplied with the product.

The filled out label must be applied to the product near the product's serial label.

 **Contiene gas fluorurati ad effetto serra inclusi nel protocollo di Kyoto**
Contains fluorinated greenhouse gases covered by the Kyoto Protocol
Enthält fluorierte Treibhausgase, die durch das Kyoto-Protokoll abgedeckt werden

D

R410A

① = Kg **A**

② = Kg **B**

① + ② = Kg **C**

③

②



F

①



E

① **Carica di refrigerante di fabbrica del prodotto: vedi targhetta con il nome dell'unità / Factory refrigerant charge of the product: see unit name plate / Werkseitige Kältemittelbefüllung des Produktes: siehe Typenschild der Einheit**

② **Quantità di refrigerante aggiuntiva nel campo / Additional refrigerant amount charged in the field / Zusätzliche am Montageort befüllte Kältemittelmenge**

③ **Carica di refrigerante totale / Total refrigerant charge / Gesamte Kältemittelbefüllung**

A Factory refrigerant charge of the product: see unit name plate

B Additional refrigerant amount charged in the field

C Total refrigerant charge

D Contains fluorinated greenhouse gases covered by the Kyoto Protocol

E Outdoor unit

F Refrigerant cylinder and manifold for charging

NOTE!

National implementation of EU regulation on certain fluorinated greenhouse gases may require to provide the appropriate official national language on the unit. Therefore an additional multilingual fluorinated greenhouse gases label is supplied with the unit.

Sticking instructions are illustrated on the backside of that label..

2.3 Proper use

The heat pump **KITA Templari®** is approved just for the intended use by the manufacturer. A different use leaving the proper one is considered non-compliant. Proper use comprende also includes the respect of the instructions contained in the relevant information material. It is forbidden to make unit changes or transformation.

2.4 Rules and legal provisions

This heat pump is intended, according the art. 1, chapter 2 k) of the EC directive 2006/42/CE (Machines Directive), to the domestic use and for this reason it is subject to the requirements of the Directive 2014/35/UE (Low voltage Directive). In this way it is intended to be used by inexperienced to heat shps, offices and more similar workplaces, in farms, hotels, guest-houses and similar or other housing structures.

In the design and realization of the heat pump all the EC directive and DIN and VDE rules (see Declaration of conformity EC) have been respected.

The electrical connection of the heat pump **KITA Templari®** has to be made according to VDE, EN and CEI current rules. Furthermore supply networks managers connection conditions have to be respected.

Concerning the connection of the heating system attenersi respect the current dispositions concerned.

People, in particular children, basing on their physical, sensory or mental ability, or because they are inexperienced or incompetent can't safely use the machine, mustn't use the machine without a responsible person's supervision and guide.

Make sure children not to play with the machine.

2.5 Energy saving

Using the heat pump **KITA Templari®** you contribute to the environmental protection. Saving energy mode is based on the correct arrangement of the system and the heat sources to use thermal energy.

Really important for the efficiency of a heat pump is to keep the difference of temperature between heating water and heat source as low as possible. For this reason it is strongly recommended an accurate sizing of the heat source and the heating system. A difference of temperature a degree Kelvin higher (one °C) causes an increaing of 2,5% about energy consumption. It is necessary to be careful, during the sizing of the heating system, to special users treatment, as for example the production of hot water, and their sizing to low temperature. The floor heating is perfect to use a heat pump thanks to low flow temperature (from 30 °C to 40 °C).

During the operation impurities aren't accumulated in heat exchangers, since they increase the difference of temperature, worsening the coefficient of performance.

3 Intended use of the heat pump

3.1 Field of work and safety devices

The heat pump **KITA Templari®** is enabled to work outside temperatures included between -22°C (for version S and M) and -32°C (for version L) and +46°C.

The machine allows following operation fields according to the temperatures of produced water:

- Heating: minimum temperature 10°C, maximum temperature 55°C
- Domestic hot water production: minimum temperature 35°C, maximum temperature 55°C
- Cooling: minimum temperature 7°C, maximum temperature 40°C.

The Kita Templari heat pump is equipped with a safety pressure switch, which interrupts the operation of the machine when a pressure of 4.05 MPa (40.5 bar) is reached.

The product is equipped with a volume flow sensor (flow meter). The flowmeter ensures that the machine stops when the water flow rate falls below the minimum threshold of 35-40% of the rated flow.

The following table shows the minimum flow and the resulting error threshold for each heat pump model:

Model	Flow meter	l/h	l/m
S/ S 3Phase	DN20	1500	27,0
S Plus/ S Plus 3Phase	DN20	1500	27,0
Si / Si 3Phase	DN20	1500	27,0
Si Cold /Si Cold 3Phase	DN20	1500	27,0
Si Plus / Si Plus Cold 3Phase	DN20	1500	27,0
Si Plus Cold / Si Plus Cold 3Phase	DN20	1500	27,0
Mi / Mi 3Phase	DN20	1500	27,0
Mi Cold / Mi Cold 3Phase	DN20	1500	27,0
Mi Plus / Mi Plus 3Phase	DN20	1800	32,4
Mi Plus Cold / Mi Plus Cold 3Phase	DN20	1800	32,4
L33	DN20	1944	32,4
L42	DN25	3026	50,4
L66	DN25	3026	50,4
L Cold	DN25	3240	54,0
Li Plus	DN32	3240	54,0

WARNINGS!

Before any maintenance works on the machine make sure to disconnect the machine from power supply.

- During summer operation a frost protection prevent water freezing of the system.
- The heat pump **KITA Templari®** is equipped with an only probe controlling the drain temperature of the compressor. The computer of the machine grants the drain temperature is more than the maximum acceptable.

NOTE!

It isn't suitable to use the machine with a frequency converter. If the machine is unplugged for long periods, don't stop the

process of oil heating starting when the machine is turned on again. This process needs to avoid that the compressor breaks.

3.2 Allowed operative zone

3.2.1 KITA with Twin Rotary KITA S - S 3phase - S plus - S plus 3phase: Heat pump

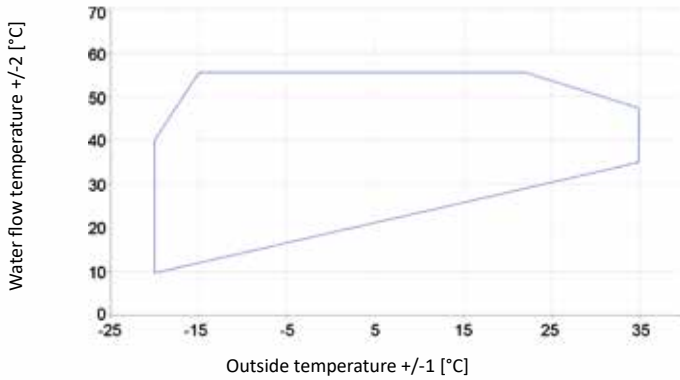

Chiller

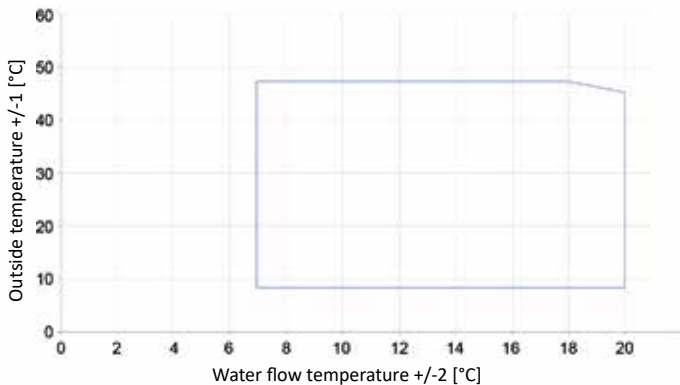

3.2.2. KITA with scroll vapour injection KITA Si - Si 3Phase - Si Cold - Si Cold 3Phase - Si Plus - Si Plus 3Phase - Si Plus Cold - Si Plus Cold 3Phase - Mi - Mi 3Phase - Mi Cold - Mi Cold 3Phase - Mi Plus - Mi Plus 3Phase - Mi Plus Cold - Mi Plus Cold 3Phase - L33 - L42 - L66 - L66 Cold - Li Plus: Heat pump

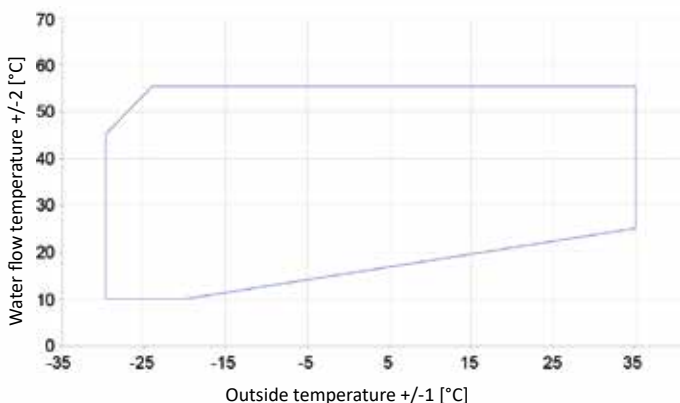

Chiller

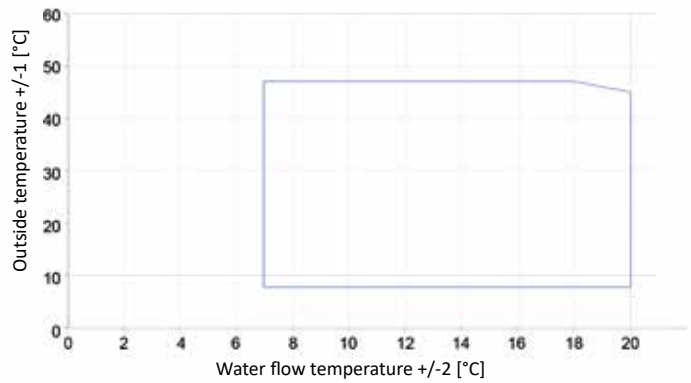

3.3 Structure of the system with heat pump

The system with heat pump includes following components:

- External unit KITA Templari® contains cooling circuit;
- Internal unit KITA Templari® contains all the components of the hydraulic circuit;
- Control command of the heating pump;
- Optional hydraulic components, that can be demanded to the manufacturer: a heating resistance for the condensate drain, a 3-way valve to the combined management of the system and domestic hot water, mesh filter, switching relay for the operation with integration boiler.

The control of machine functions is totally made by command.

3.4 Components

KITA S - S 3phase - S plus - S plus 3phase - Si Cold - Si plus Cold - Si Cold 3phase - Si plus Cold 3phase - Mi - Mi 3phase - Mi Cold - Mi Cold 3phase: circulator Wilo Para 25/8 iPWM

Model	Wilo Para 25/8 iPWM
Voltage - supply frequency	1-230-V 50/60Hz
Energy efficiency index (EEI)	≤0,21
Maximum power	75 W
Maximum current absorption	0,6 A
Maximum head	8,4 m
Minimum pressure input	0,5 m
Producible water temperature	Da -10°C a 95°C

Characteristic curves of the Circulator

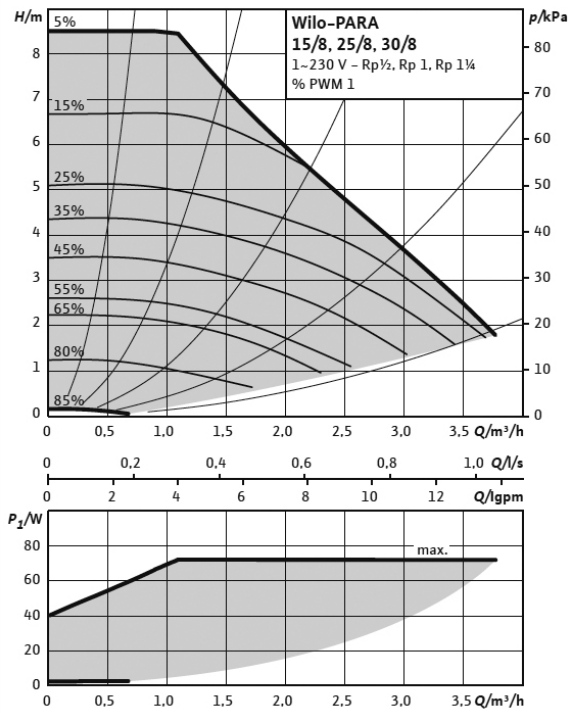

Pressure drop in the plate heat exchanger

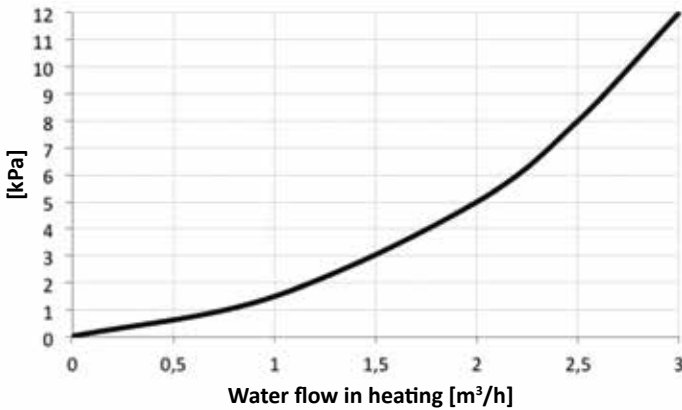

3.5 Components

KITA Mi plus - Mi plus 3phase - Mi plus Cold - Mi plus Cold 3phase - L33: circulator Wilo Para 25/9 iPWM

Model	Wilo Para 25/9 iPWM
Voltage - supply frequency	1-230-V 50/60Hz
Energy efficiency index (EEI)	≤0,21
Maximum power	87 W
Maximum current absorption	0,7 A
Maximum head	9,0 m
Minimum pressure input	0,5 m
Producible water temperature	Da -10°C a 95°C

Characteristic curves of the Circulator

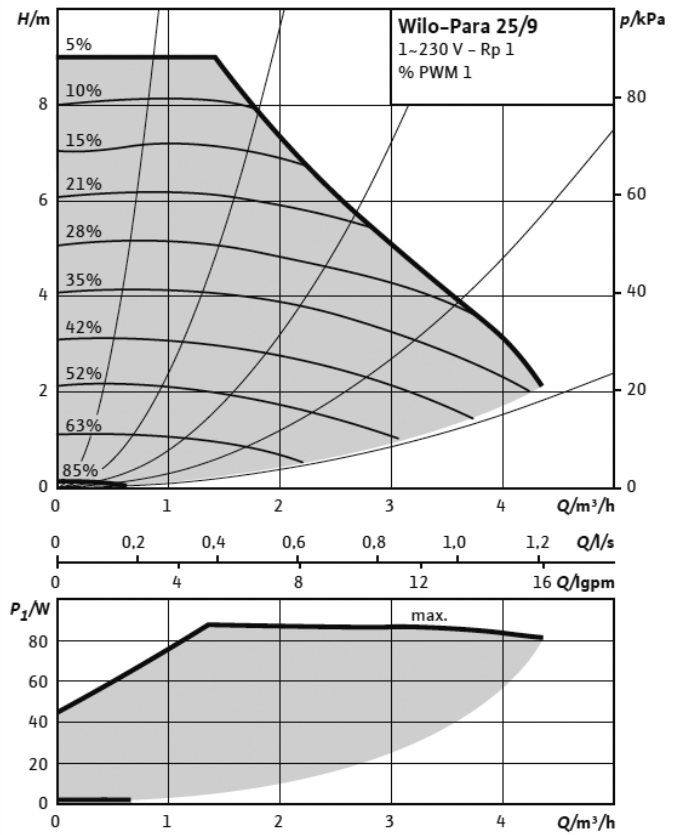

Pressure drop in the plate heat exchanger

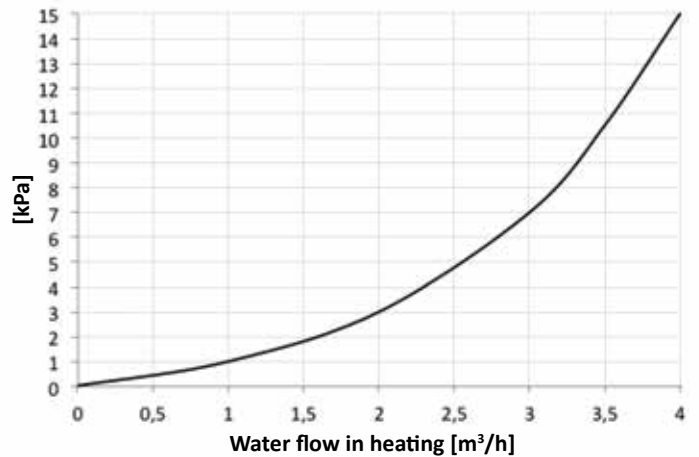

3.6 Components

KITA L42, L66

Model	Grundfos UPMXL GEO 25-125 180
Voltage - supply frequency	1 x 230 V, 50 Hz
Energy efficiency index (EEI)	≤ 0.23
Maximum power	3-180 W
Maximum current absorption	0,06 - 1,4 A
Minimum pressure input	0,5 bar
Producible water temperature	From -10°C to 95°C

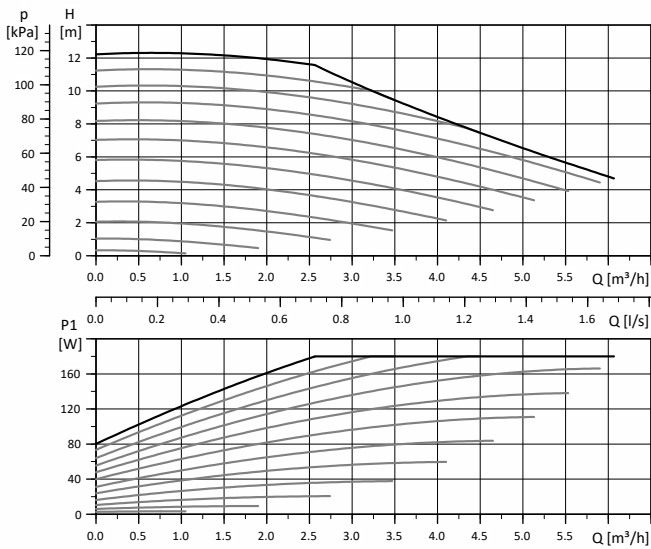

3.7 Components KITA Li PLUS

Model	Wilo Yonos Para HF 30/12
Voltage - supply frequency	1~230V ± 10%, 50/60Hz
Energy efficiency index (EEI)	≤ 0,23
Maximum power	10 - 305 W
Maximum current absorption	0,15 - 1,33 A
Maximum head	11 m
Minimum pressure input	0,5 bar
Producible water temperature	From -20°C to +110°C

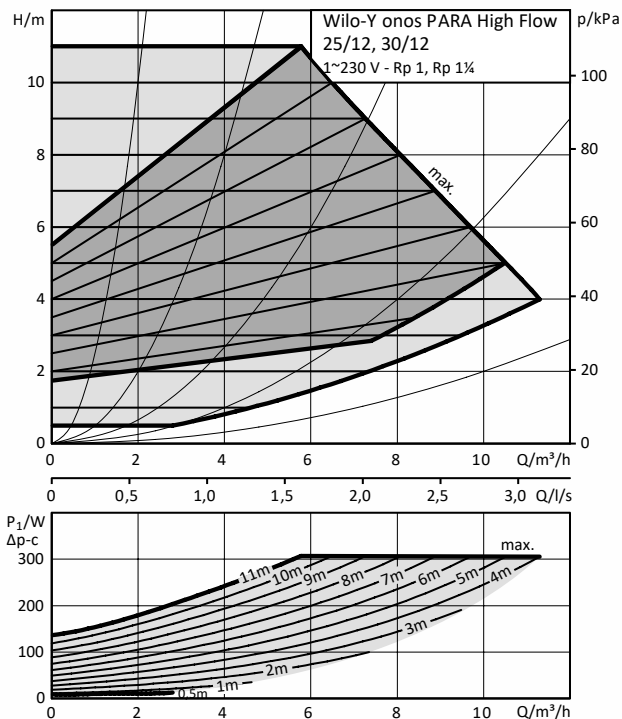

3.8 Operation mode

The heat pump can work according two modes, actionable through the commutation of 4-way valve: as explained below, these modes are heating and cooling/defrosting. It's also possible to insert a suitable management mode DHW (domestic hot water) composed by relays, temperature sensors and 3-way valve. For this reason the pump can manage the domestic as a priority both in summer than in winter.

figure 1 Heating mode

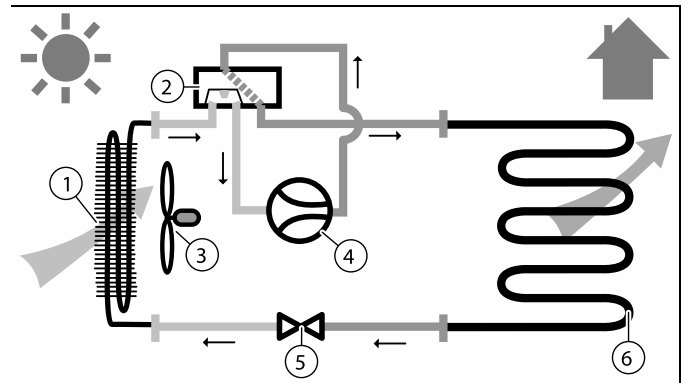

- | | | | |
|---|-------------|---|----------------------------|
| 1 | Evaporator | 5 | Electronic expansion valve |
| 2 | 4-way valve | 6 | Plate heat exchanger |
| 3 | Fan | | |
| 4 | Compressor | | |

Heating and cooling mode

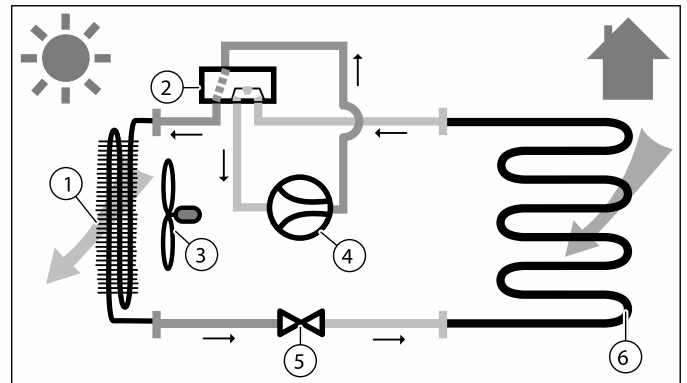

- | | | | |
|---|-------------|---|----------------------------|
| 1 | Evaporator | 5 | Electronic expansion valve |
| 2 | 4-way valve | 6 | Plate heat exchanger |
| 3 | Ventilator | | |
| 4 | Compressor | | |

4 Scope of supply

4.1 Main unit

The heat pump KITA Templari® is supplied in 2 unit and it is composed by the components shown in figure 1.

4.2 Type name and serial number

Model name and serial number are on the plate (1) figure 1.

figure 1

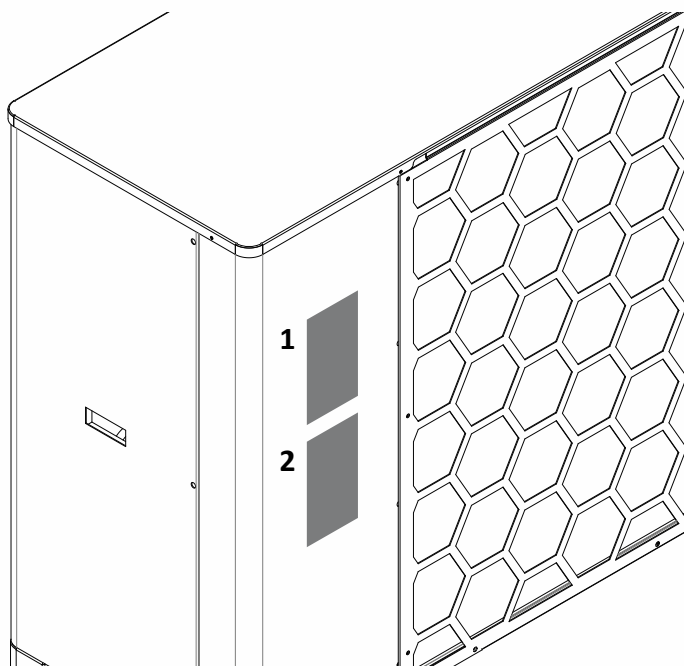

LABELS

- 1 – identification label
2 – refrigerant charge label

1 – identification label

2 – refrigerant charge label

 Contiene gas fluorurati ad effetto serra inclusi nel protocollo di Kyoto
 Contains fluorinated greenhouse gases covered by the Kyoto Protocol
 Enthält fluorierte Treibhausgase, die durch das Kyoto-Protokoll abgedeckt werden

R410A

① = Kg

② = Kg

① + ② = Kg

③

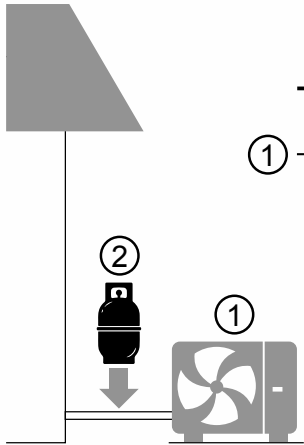

① Carica di refrigerante di fabbrica del prodotto: vedi targhetta con il nome dell'unità / Factory refrigerant charge of the product: see unit name plate / Werkseitige Kältemittelbefüllung des Produktes: siehe Typenschild der Einheit
 ② Quantità di refrigerante aggiuntiva nel campo / Additional refrigerant amount charged in the field / Zusätzliche am Montageort befüllte Kältemittelmenge
 ③ Carica di refrigerante totale / Total refrigerant charge / Gesamte Kältemittelbefüllung

To fill in the gas refrigerant label, make reference to par. 2.2

 Templari srl
 Via Pitagora 20/A 35030 Rubano - PD
 info@templari.com +39 049 5225929

Wärmepumpe / Heat pump/Chiller / Pompa di calore

Model / Model / Modello	KITA M SPLIT
Baujahr / time of production / Anno di fabbricazione	2020
Wärmeleistung / Heating Capacity / Potenza nominale a pieno regime in riscaldamento	16,58 kW
Kühlleistung / Cooling Capacity / Potenza nominale a pieno regime in raffreddamento	13,50 kW
Anschluss-Spannung / Supply / Alimentazione	230V / 50Hz
Maximaler Laststrom / Maximum Input Current / Massima corrente assorbita	29A cosφ 0,9
Gewicht / Weight / Peso netto OUTDOOR - INDOOR	200 / 50 kg
DGRL Kategorie / PED Category / Categoria PED	I
R410a Kältemittelmenge / Refrigerant Charge R410A / Refrigerante R410a	6,5 kg
CO ₂ -Äquivalent / CO ₂ equivalents / CO ₂ equivalente	13.572 Kg
Maximal zulässigen Druck / Max pressure permissible / Pressione massima ammissibile	Hp: 45 bar Lp: 30 bar
Kompressortyp / Compressor type / Tipo compressore	Inj

Hinweis: die Wärmeleistung wurde in Standardkonditionen geprüft, mit trockene/nasse Testspitze 7 (6)°C, Wassertemperatur in/out 30/35°C. Die Kühlleistung wurde in Standardkonditionen geprüft, mit trockene Testspitze 35°C, Wassertemperatur in/out 18/23°C. Leistungswerte nach den Norm EN14511.

Nota: Heating capacity tested in standard condition of temperature: external 7/6°C dry/wet bulb and 30/35°C water inlet/outlet temperature Cooling capacity tested in standard condition of temperature: external 35°C dry bulb and 18/23°C inlet/outlet water temperature Tests in accordance with EN14511.

Nota: La capacità di riscaldamento è stata testata in un ambiente standard con temperatura di test di bulbo secco/bagnato 7 (6)°C temperatura dell'acqua in/out 30/35°C. La capacità di raffreddamento è stata testata in un ambiente standard con temperatura di test di bulbo secco 35°C temperatura dell'acqua in/out 18/23°C. Valori di potenza resa in accordo con norma EN14511.

S.N. K001713



4.4 Component scheme of external unit of heat pump LINE KITA L Templari®

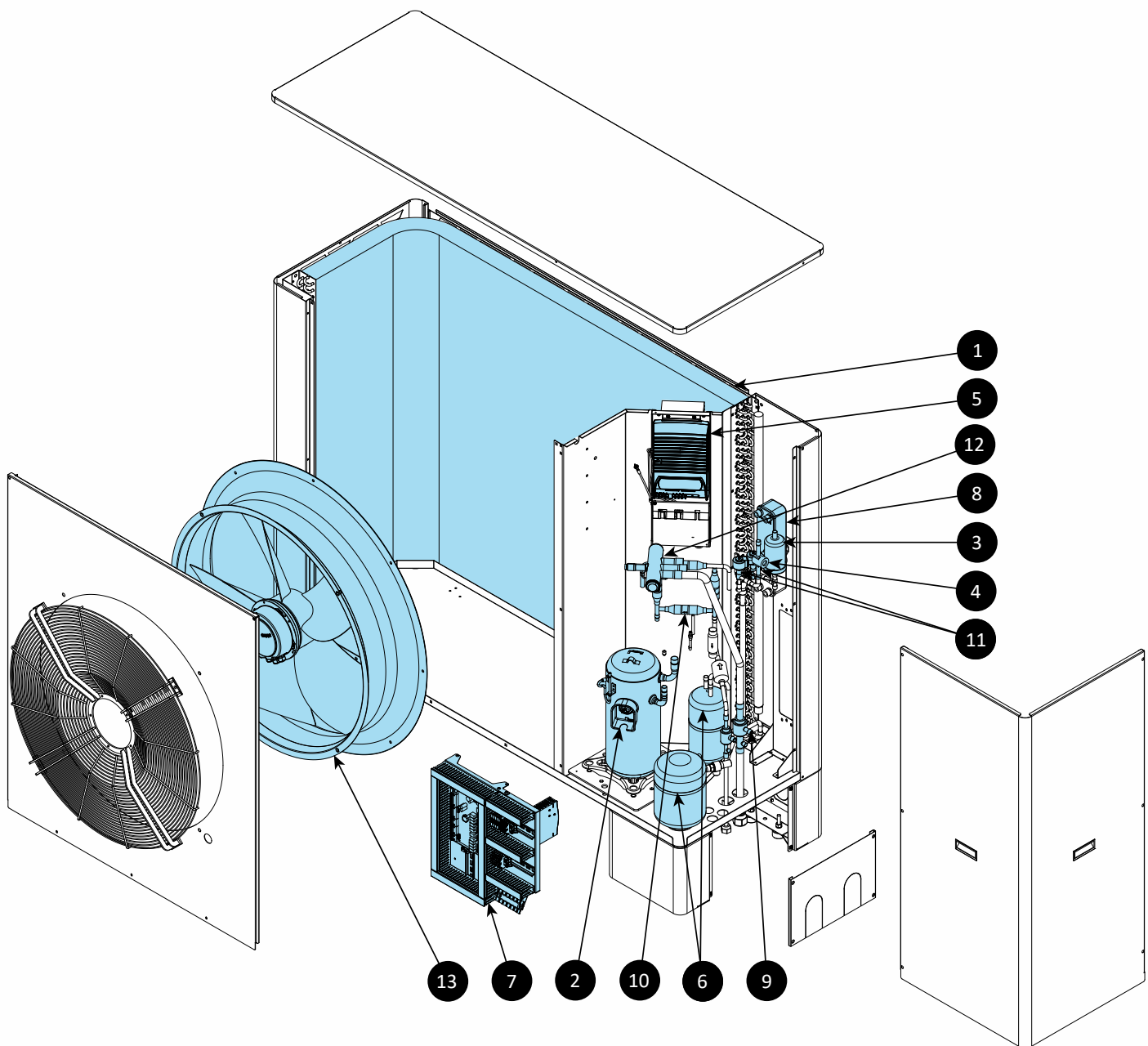

1	EVAPORATOR	9	BALL VALVES
2	COMPRESSOR	10	CHECK VALVES
3	FILTER	11	ELECTRONIC EXPANSION VALVE
4	LIQUID INDICATOR	12	4-WAY VALVE
5	INVERTER	13	FAN
6	LIQUID RECEIVER		
7	ELECTRIC BOARD		
8	ECONOMIZER		

The image is intended only to indicate the main internal components. The actual product may look different.

4.5 Components scheme of heat pump KITA Li Plus Templari® external unit

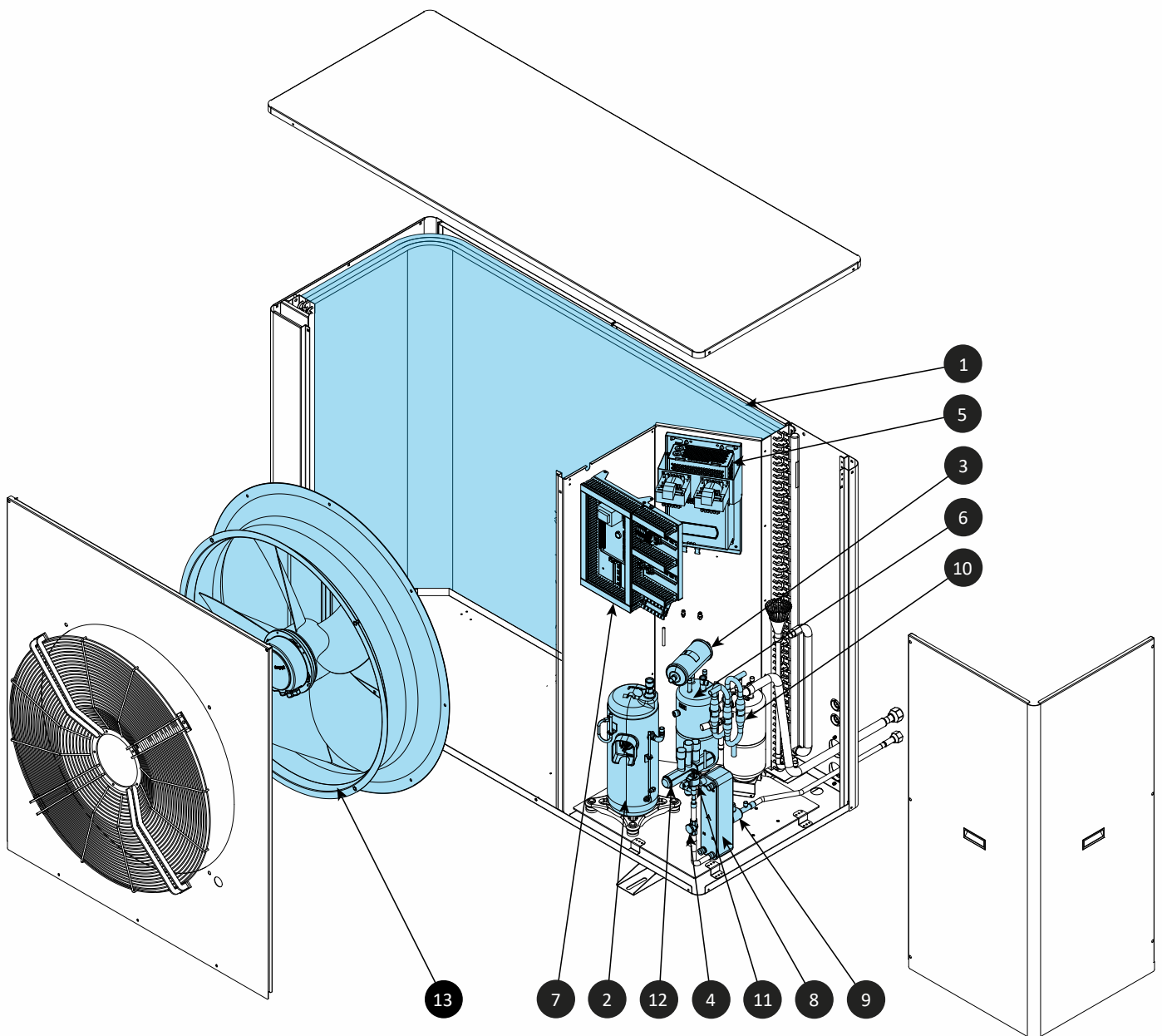

- 1 EVAPORATOR
- 2 COMPRESSOR
- 3 FILTER
- 4 LIQUID INDICATOR
- 5 INVERTER
- 6 LIQUID RECEIVER
- 7 ELECTRIC BOARD
- 8 ECONOMIZER

- 9 BALL VALVES
- 10 CHECK VALVES
- 11 EXPANSION VALVE
- 12 4 - WAY VALVE
- 13 FAN

The image is intended only to indicate the main internal components. The actual product may look different.

4.6 Components scheme of heat pump KITA S/Si/Mi/L Templari® internal unit

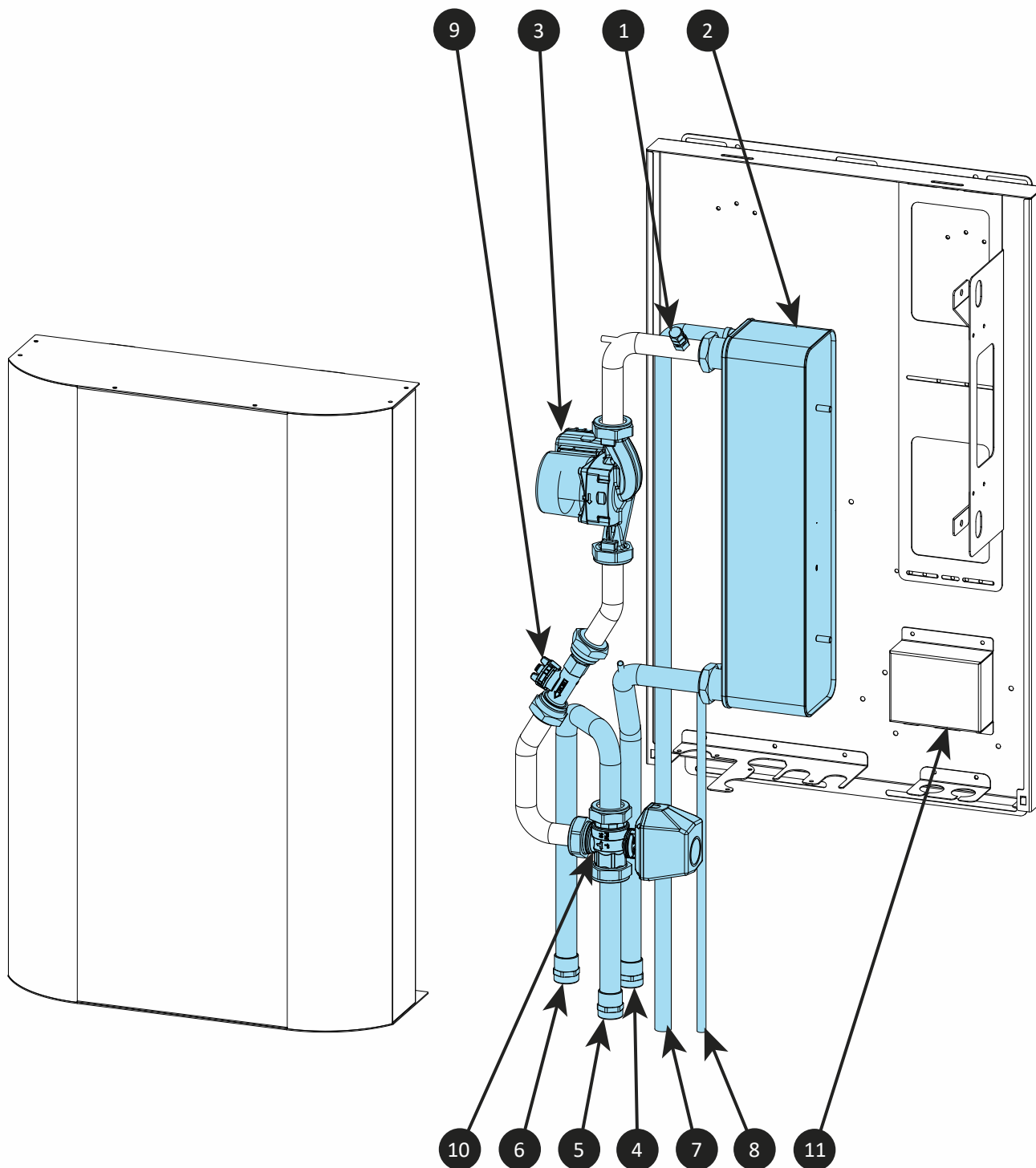

- 1 RELEASE VALVES
- 2 PLATE HEAT EXCHANGER
- 3 CIRCULATION PUMP
- 4 WATER INLET PIPE
- 5 WATER OUTLET PIPE (PLANT)
- 6 WATER OUTLET PIPE (DHW)

- 7 PIPE GAS
- 8 PIPE LIQUID
- 9 FLOW METER
- 10 3-WAY VALVE *
- 11 ELECTRIC BOARD

The image is intended only to indicate the main internal components. The actual product may look different.

4.7 Components scheme of heat pump KITA Li Plus Templari® internal unit

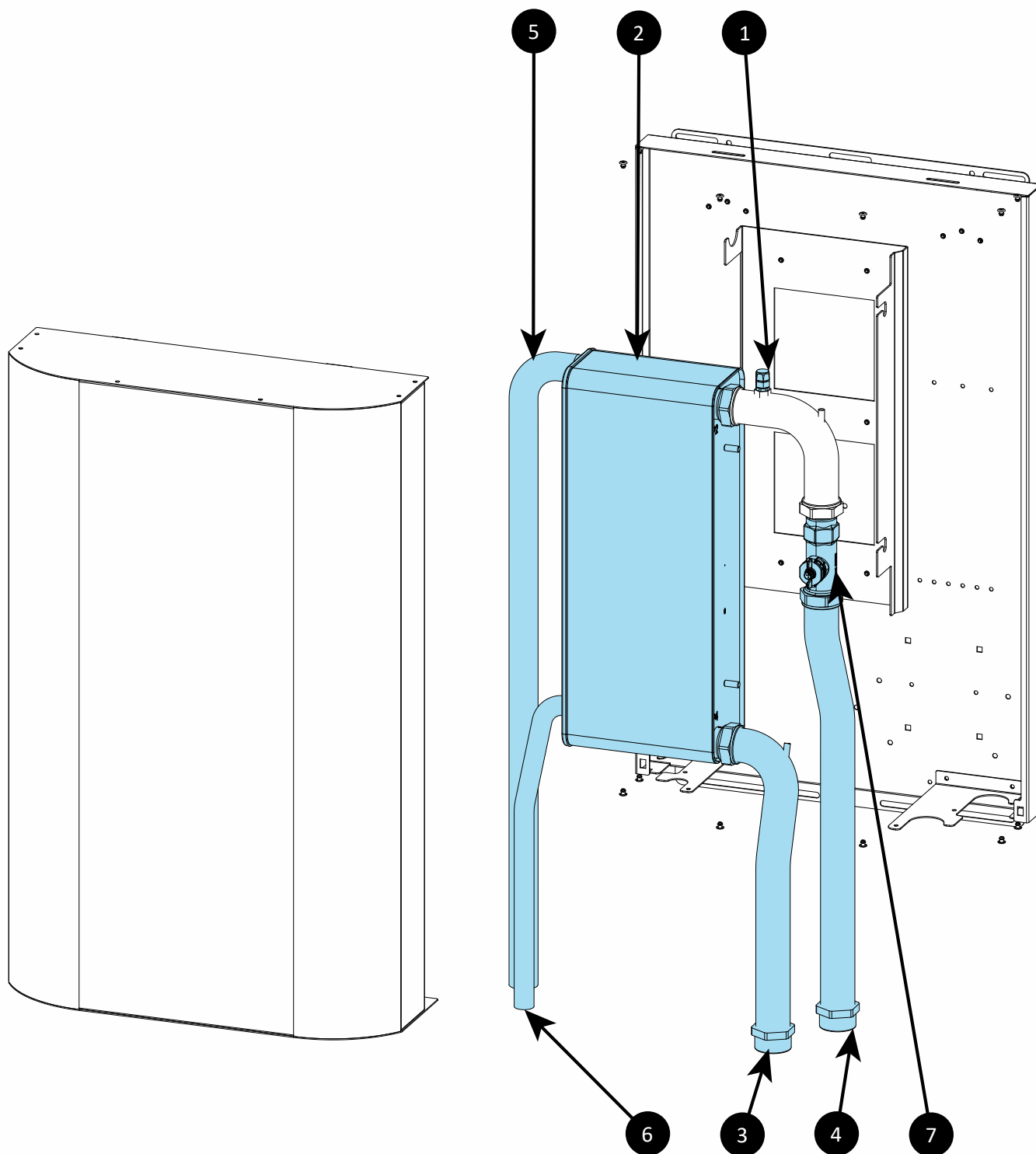

- 1 RELEASE VALVES
- 2 PLATE HEAT EXCHANGER
- 3 WATER OUTLET PIPE (SYSTEM)
- 4 WATER OUTLET PIPE (DHW)

- 5 PIPE GAS
- 6 PIPE LIQUID
- 7 FLOW METER

The image is intended only to indicate the main internal components. The actual product may look different.

5 Transport

WARNINGS!

Independently from the type of transport, the heat pump can never be tilted more than 45°. Contrary, In the next operation you can find faults in the refrigerant circuit. In severe cases it can cause an internal fault.

The transport to final installation place should be made on pallet. The heat pump **KITA Templari®** can be transported by a forklift.

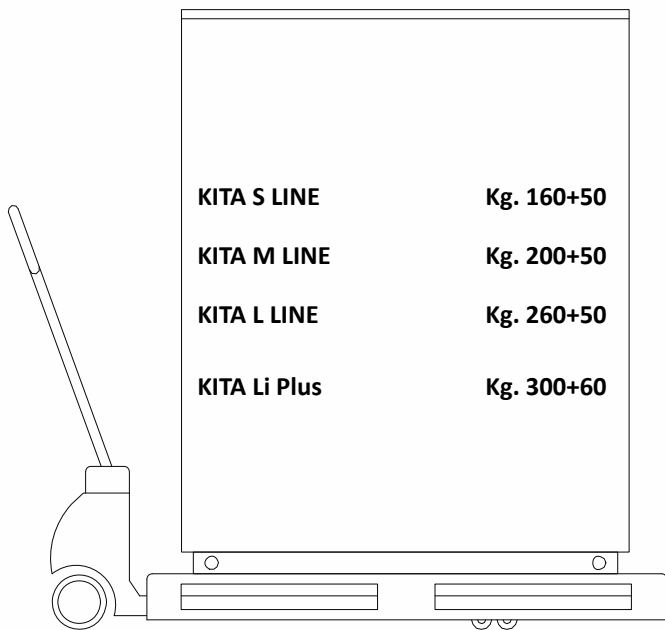

- Protect the side walls of the product in contact with the forklift to avoid scratches and damages.
- Lift the product only from the back and fittings side.
- The lift of excessive weights can cause injuries, for example vertebral columns.
- Consider the weight of the product mentioned in the technical data.
- For transport of heavy load, respect the dispositions and the current rules.
- Lifting the external unit it is recommended to be careful to excessive efforts. For this reason we suggest the collaboration of two people at least .

6 Assembly and installation

6.1 Components supplied

- cable to control panel link
- temperature probes
- bracket for wall mounting of indoor unit

optionals on demand

- Circulator for hydraulic system;
- Antivibration supports for ground fixing;
- Y filter;
- Antivibration supports for piping.

6.2 External unit sizes

KITA S LINE

WITH LEGS

Bottom view

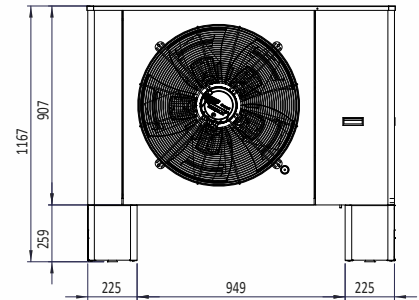
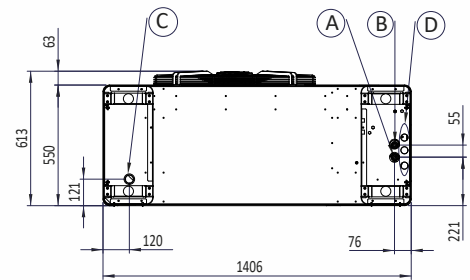

WITH BRACKETS

Bottom view

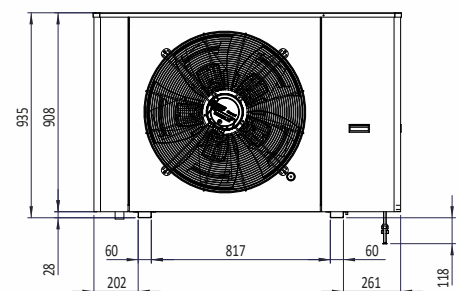
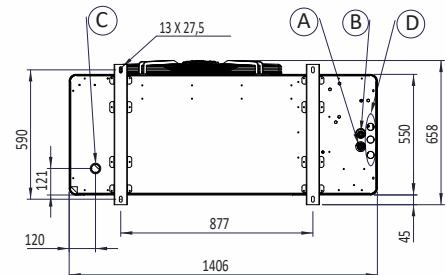

- A: gas flow - outer diameter: 12 mm
- B: refrigerant liquid flow - outer diameter: 10 mm
- C: condensate drain - outer diameter 40 mm
- D: electrical wiring

KITA SERIE M

WITH LEGS

Bottom view

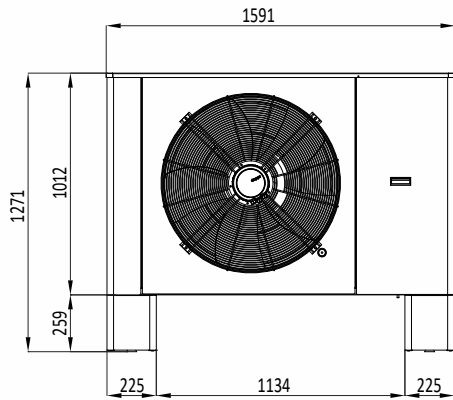
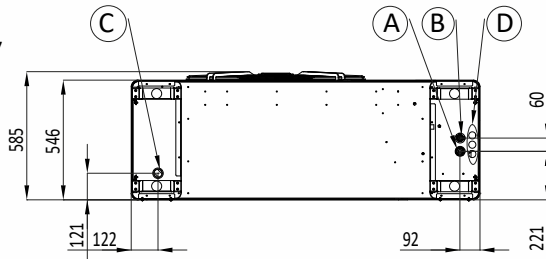

WITH BRACKETS

Bottom view

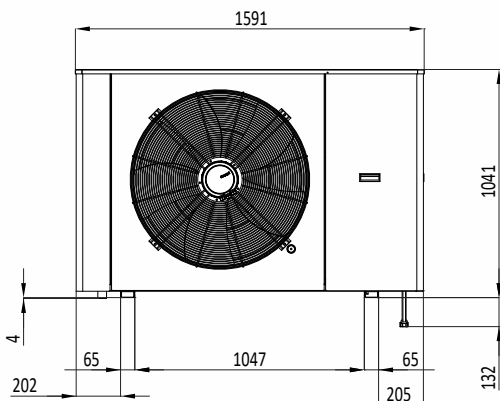
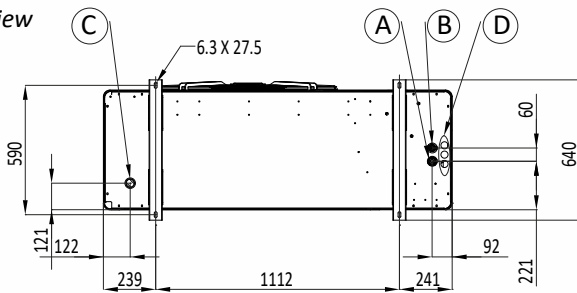

- A: gas flow - outer diameter: 18 mm
- B: refrigerant liquid flow - outer diameter: 12 mm
- C: condensate drain - outer diameter 40 mm
- D: electrical wiring

KITA SERIE L

WITH LEGS

Bottom view

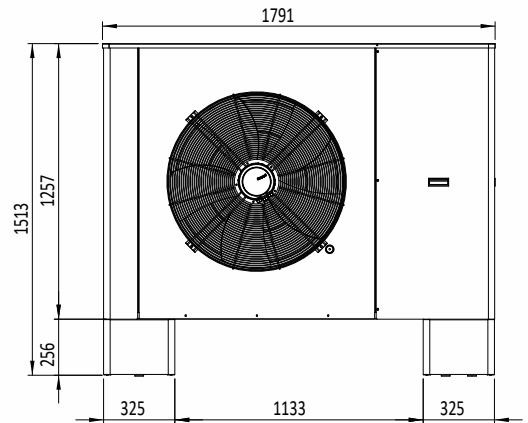
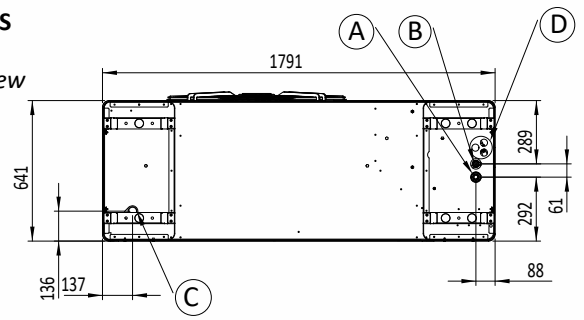

WITH BRACKETS

Bottom view

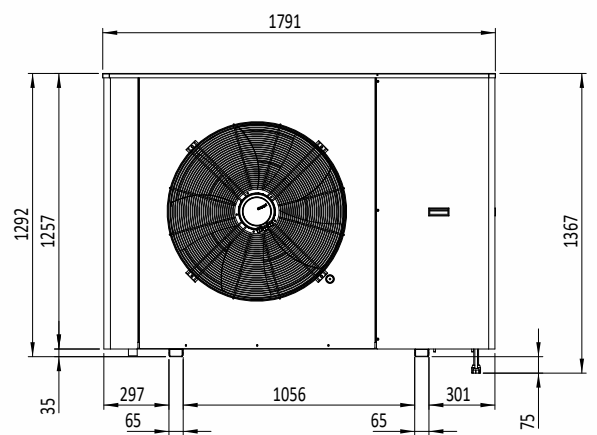
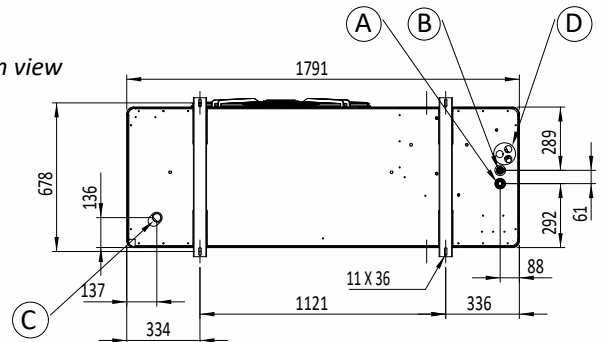

- A: gas flow - outer diameter: 22 mm
- B: refrigerant liquid flow - outer diameter: 12 mm (L42-L66 16 mm)
- C: condensate drain - outer diameter 40 mm
- D: electrical wiring

- Prepare cable laying.
- In places where there are snowfalls, instal the heat pump 25 cm from the floor at least to avoid obstruction of the suction zone and the condensate drain.

6.5 Outdoor unit assembly

1. Before installing the product, respect the safety warnings contained in this manual and in service manuals.
2. Assembly the product on steel beams, concrete blocks or helped by a wall support (optional).
3. Verify that water isn't accumulate under the product.
4. Verify that the pavement in front of the product can well absorb the water to avoid ice formation.

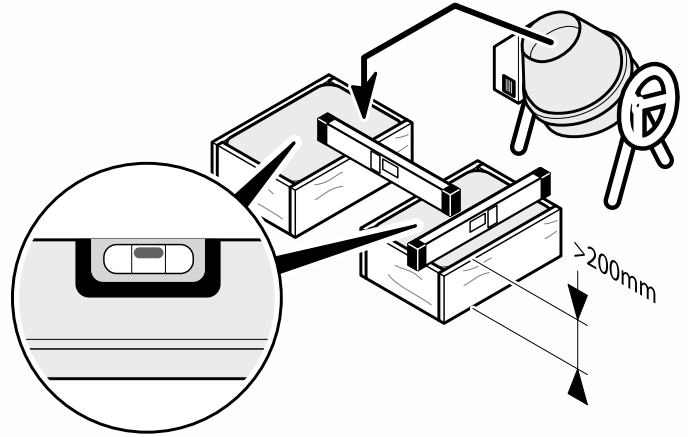

6.6 Preparation of condensate drain

The condensate is drained in a centralized way from the back of the heat pump KITA Templari®.

Prepare the condensate drain by drain pipe or gravel bed.

⚠ WARNINGS!

The frozen condensate on the avenues can cause falls. Verify the condensate isn't drained on the avenues being able to freeze on these.

- *Basement preparation of condensate drain*

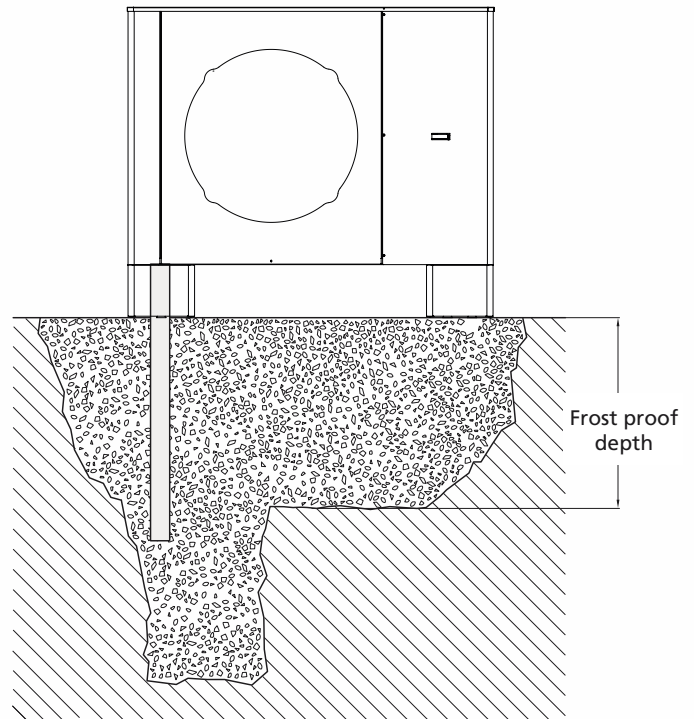
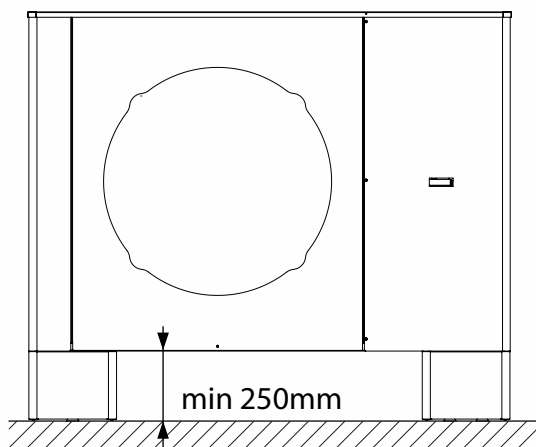
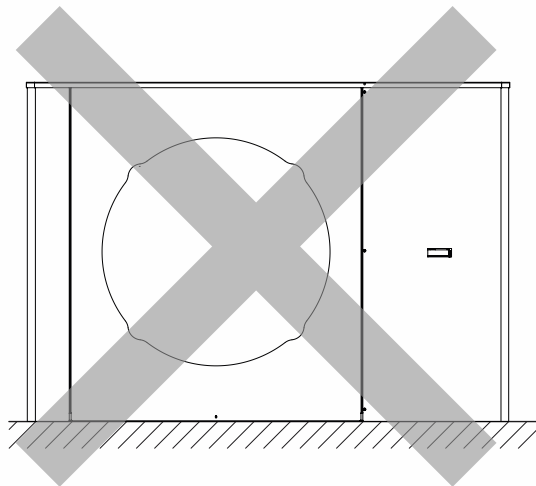

- *Example 1 condensate drain (it is suitable to inter the condensate drain tube to avoid if you don't buy the heating resistance for condensate drain as optional).*

6.7 Alignment of the outdoor unit

Put the heat pump **KITA Templari®** horizontal so that the condensate can outflow. The product has to be installed with the amortized feet enclosed. The amortized feet increase the height of the product, facilitating the outflow of the condensate and reducing the vibrations.

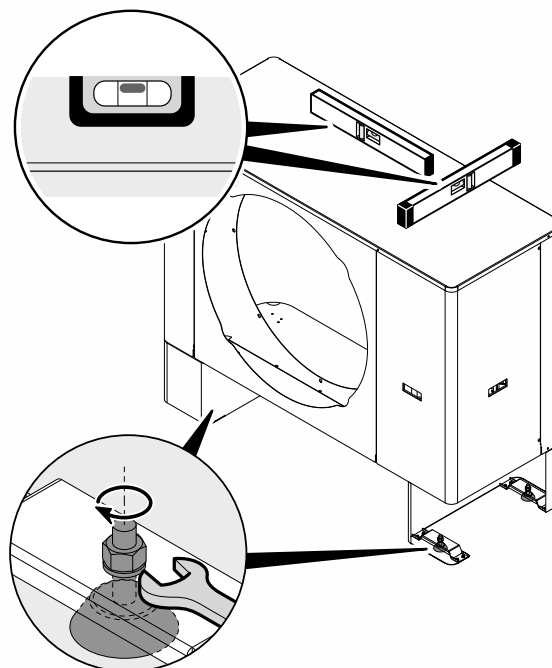
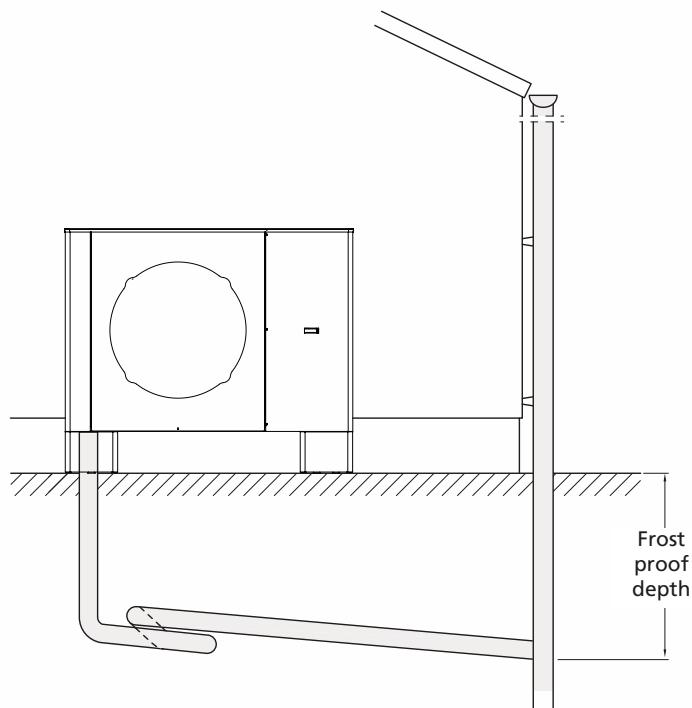

- *Example 2 condensate drain*

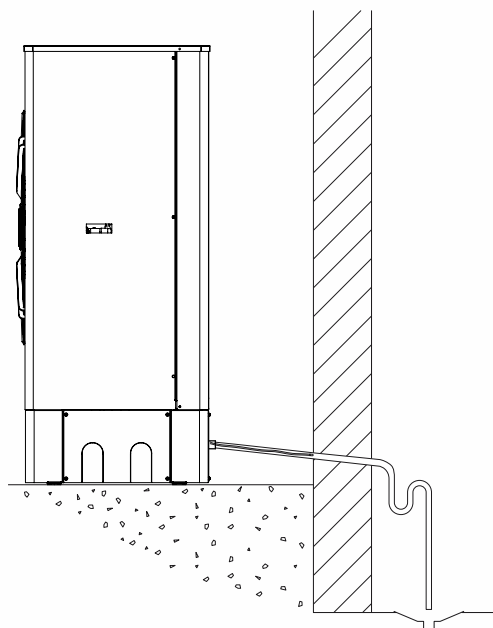

- *Example 3 condensate drain with condensate drain resistance*

The condensate drain accumulating during the operation has to be drained away so that it can freeze. To grant the correct outflow the heat pump has to be horizontal. The water condensate tube has to have a minimum diameter of 18mm and has to flow in the drain canal so that it can't freeze. Don't drain the condensate directly into sewage basins and ditches. The aggressive steam and the condensate pipe, if not frost-protected, can cause irreparable damages to the evaporator.

In places where there are snowfalls, instal the heat pump 25 cm from the floor at least to avoid obstructions of the aspiration zone and the condensate drain.

6.8 Probe installation

All probe used for the operation of the plant must be installed properly in the appropriate wells using a suitable thermal paste.

⚠ WARNINGS!

Installing the probes not in a proper way will voids the warranty.

7 Assembly and installation of the indoor unit

The indoor unit is the interface between the outdoor unit and the heating/cooling system of the building, and it contains all the hydronic components necessary to transfer thermal energy.

7.1 Sizes and components of the indoor unit

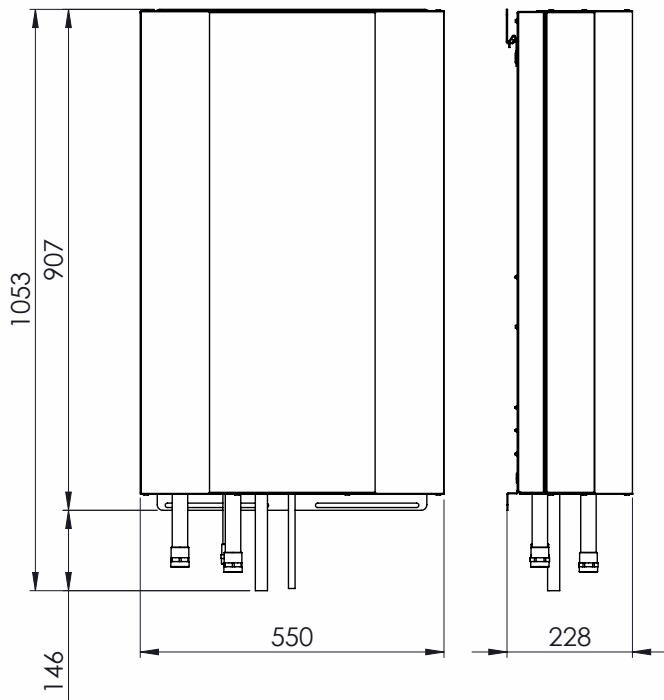

Threaded water connections 1" M

With DHW

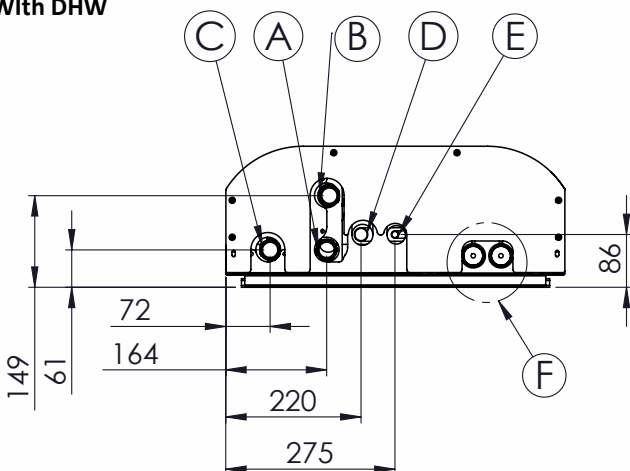

Without DHW

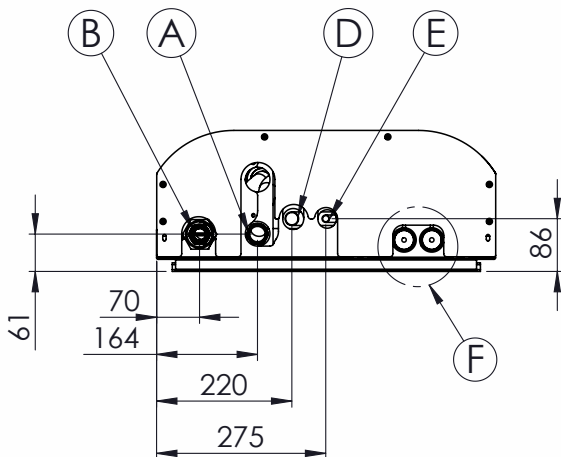

- A: water inlet - connection $\varnothing 1''$
- B: water outlet (plant) - connection 1"
- C: water outlet (DHW) - connection 1"
- D: gas flow - outer diameter: has shown in data table page 23
- E: liquid flow - outer diameter 12mm
- F: electrical wiring

Mounting wall bracket

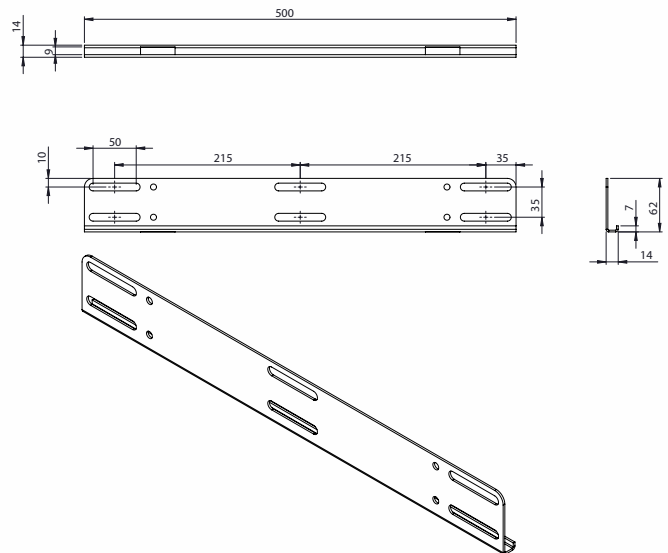

7.2 General information and choice of the place to instal the indoor unit

⚠ WARNINGS!

It is suitable to instal a security valve on the hydraulic system. The assembly of the security valve has to be made by a qualified staff

- Instal the hydronic unit indoor.
- The hydronic unit can't be installed near heating or steam sources. Besides it is suitable not to instal the unit in humid environments.
- Instal the indoor unit respecting the minimum distances from walls and obstacle to facilitate mounting and maintenance operation.
- Grant a correct air flow.
- Instal the hydronic unit in a vertical position, as shown in figure paragraphe 7.1.

7.3 Assembly of the indoor unit

The hydronic unit has to be fixed on the wall by anchors and L supports, getting a grip on the back bracket of the carpentry. On the bottom of the carpentry there is another support for a definitive and sure anchorage.

- the drilling for the support has to respect the mentioned sizes.
- Lift the unit and hang it on the wall. More than a person is needed, since the heavy weight can cause injuries.

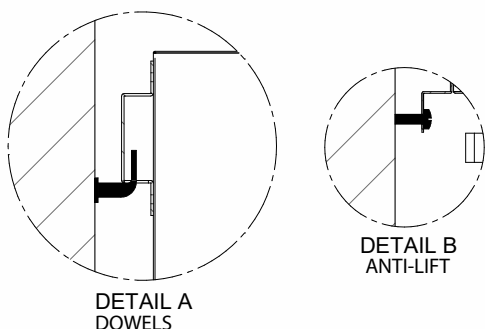
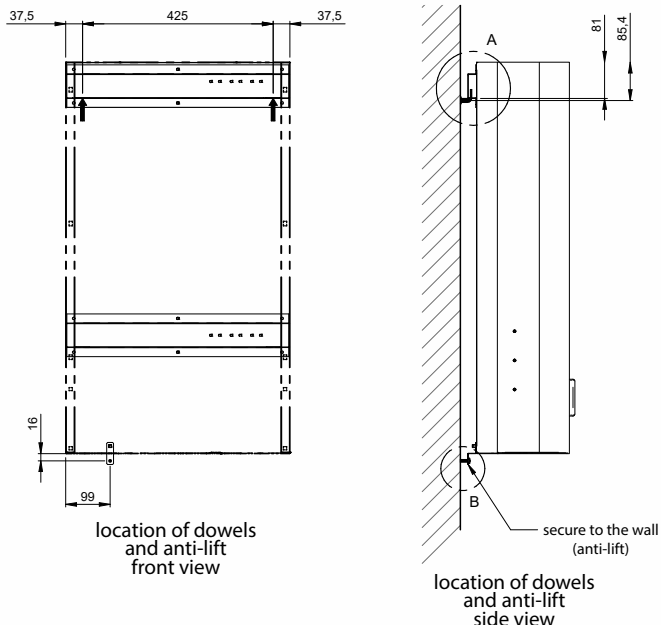

16 + 16 = 32 total meters
 32 meters x 15 g / m = 480 total grams

	Nominal Length	Maximum length of the piping (m of equivalent length)	Maximum height difference (m of equivalent length)
All models	1	30	30

Sub-cooling must be in a range between 3°C and 4°C with heat pump in steady state.

i NOTE!

The parameter equivalent length has to consider the curves too. Each 90° curve in the circuit has to be counted as a 1 m straight portion. Each 180° curve in the circuit has to be counted as a 2 m straight portion. Each oil trap in the circuit has to be counted as a 4 m straight portion.

8.2 Preparing for installation and installation of refrigerant pipes

The connections of refrigerant pipes have to be sealed to avoid the spillage of the refrigerant and the consequent malfunction of the heat pump. The connection pipes have to be isolated and have diameters specified in the following chart.

	Gas (mm)	Liquid (mm)
KITA S/S Plus/Si/Si Cold/Si Plus/Si Plus Cold	Ø12	Ø10
KITA Mi/Mi Plus/ Mi Cold/Mi Plus Cold	Ø18	Ø12
KITA L33	Ø22	Ø12
KITA L 42/L66/L Cold	Ø22	Ø16
KITA Li Plus	Ø28	Ø16

8 Connections of the refrigerant circuits

the connection of refrigerant pipe has to be made by an authorized and competent staff. The connection requires the use of a tool for welding.

8.1 Installation requirements

- The connection tubes between the indoor and outdoor unit have to respect the sizes mentioned below.
- Not to respect the indication mentioned can cause a significant decrease of the machine performance and it can lead to incorrect operation.
- When there is a difference in height of more than 4 meters between indoor and outdoor units, it will be necessary to provide some special siphon every 4 meters high on the refrigerant flow piping to help the flow of the oil possibly dispersed in the circuit.
- Estimated amount of additional refrigerant liquid R410A

Gas (mm)	Liquid (mm)	Amount of gr to add for each meter *
12	10	15,00 g/m
18	12	25,00 g/m
22	12	30,00 g/m
22	16	50,00 g/m
28	16	60,00 g/m

* sub-cooling must be in a range between 3°C and 4°C with heat pump in steady state.

Example: in the case of a line with pipes with a diameter of 12mm gas and a length of 16 linear meters and pipes with a diameter of 10mm for the liquid of 16 linear meters, the amount of refrigerant to be added will be:

! WARNINGS!

The heat pump is equipped with operating cocks and valves only for maintenance or welding work.

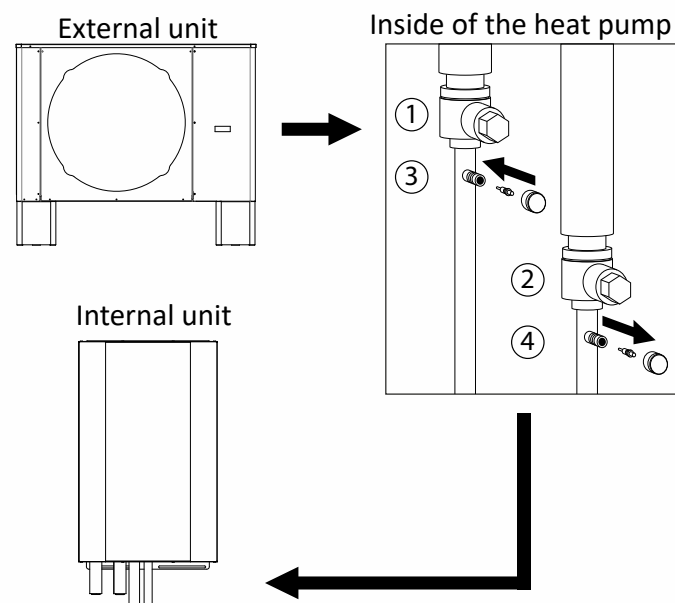

①② Taps

Used to isolate the refrigerator circuit R410A during void procedure or welding with a stream of nitrogen.

③④ Service valves

They must be used exclusively for the focusing operation of the internal vacuum split refrigerant circuit with associated piping, to perform welding with a stream of nitrogen or for commissioning of the inner split pressure to find any leaks (nitrogen).

The service valves are not load valves and should not be used under any circumstances to load or unload the gas R410A of the machine.

To prepare the pipes for installation, proceed as follows:

- Measure the distance between the indoor and outdoor unit, and make all the curves necessary to the installation.
- The pipe-laying has the lowest number possible of curves, because each curve increases the circuit flow losses and reduces the performances of the machine.
- Cut the pipes slightly longer than the measure.
- Completely remove the smears of the cutting section, keeping the tube tilted downward and blowing air into the tube.
- Respect the length sizes showed in the chart, or add the quantity of refrigerant demanded.
- Weld the brackets supplied by the manufacturer at the end of the connection tube. Weld the inner side female connections and the male connections outer side. Where possible perform the weld in a nitrogen atmosphere.
- Check that for each connection the teflon gasket provided is present
- Carefully isolate refrigerant connections.

8.3 Void procedure

- We suggest to do a leak test in nitrogen at 40 bar to verify if the connections and welding are good.
- To make the void, connect the pump to charge connections in the outdoor unit.
- Perform the void procedure till to reach a pressure of 0,4 mbar (procedure duration about 1 h for total connections length equal to 15 m. If the length increases for consequence the duration of the void procedure will increase)
- At the end of the procedure, close the tap of the vacuum pump, and fill in a minimum amount of refrigerant gas by acting on the taps to pressurize the pipes before unplugging the pump. Then open the taps to drain the refrigerant gas.

9 Hydraulic connections

A correct installation of the hydraulic connections is fundamental to grant the nominal performances of the machine. For this purpose some indications about proper processes and components are furnished as follows.

9.1 General information

1. Make sure the unit is in balance and correctly positioned before making any operation. Always adopt protection device.
2. Isolate all the connection hydraulic pipes to avoid losses of heat energy.
3. If the product isn't installed on the highest point of the circuit, then install in a suitable point some additional vent valves.
4. Install on the return of the heat circuit, between two shut-off valves, a dirt protection filter to clean regularly
5. For the connection of the piping, see the destination of each tube in the figure below

With ACS

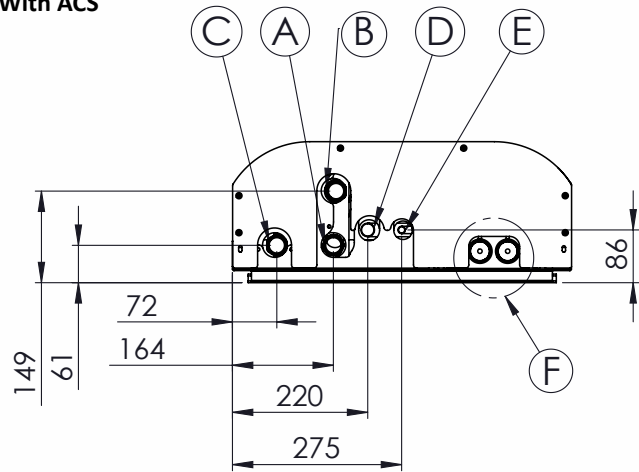

Without DHW

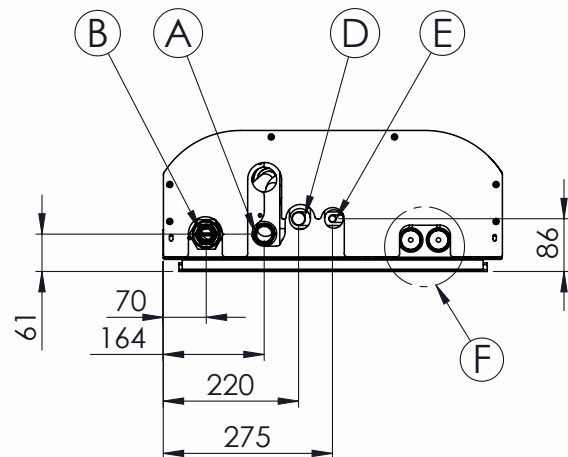

- A: water inlet - connection $\varnothing 1''$
- B: water outlet (plant) - connection 1"
- C: water outlet (DHW) - connection 1"
- D: gas flow - outer diameter 22mm
- E: liquid flow - outer diameter 12mm
- F: electrical wiring

9.2 Special components

The installer has to make the choice of the necessary system components, we will show here below some useful device for the operation of the machine:

- Shut off valves incoming and outgoing the circuit allows maintenance operations no draying the system;
- Security valve hydraulic side.
- Thermometers and pressure gauges incoming and outgoing the main components grant a better monitoring and facilitate the maintenance;
- Vent valves in the highest system points grant the air vent from the circuit;
- Drain taps on the bottom of the system to facilitate the drain;
- Expansion vessel to keep the right water pressure compensating for thermal expansions has to be sized considering the total volumes of water in the system;
- A Y filter installation is necessary.

⚠ WARNINGS!

Installare a security valve on the thermal side.

9.3 Installation of the hydraulic part

- Accurate system washing with clean water filling and emptying several times. This operation allows to reduce the number of maintenances and avoid damages to the exchangers and other components;
- Prove of the possible losses in the circuit;
- Isolate all the pipes to reduce heat dispersion and avoid the formation of condensate;
- Let the service points free like wells, vent, etc...;
- Verify water quality is proper, contrary you can have penalization of the performances, higher flow losses, possibility of damages.

Reference values: see table section 10.3

9.4 Choice of the system diagram

Make reference to the shown schemes in the following pages to the realization of the circuit basing on your own exigencies and adapting it to contest of installation.

WARNINGS!

The buffer, if on outlet pipe, must always comply with a minimum quantity of liters according to the heat pump KITA used:

KITA S 200 Liters

KITA M 300 Liters

KITA L 500 Liters

WARNINGS!

If you have a pressure drop of more than 7 meters it is mandatory to use an increased circulator.

WARNINGS!

Probe B2, when used, must always be placed in a buffer mounted on outlet pipe, never inlet.

WARNINGS!





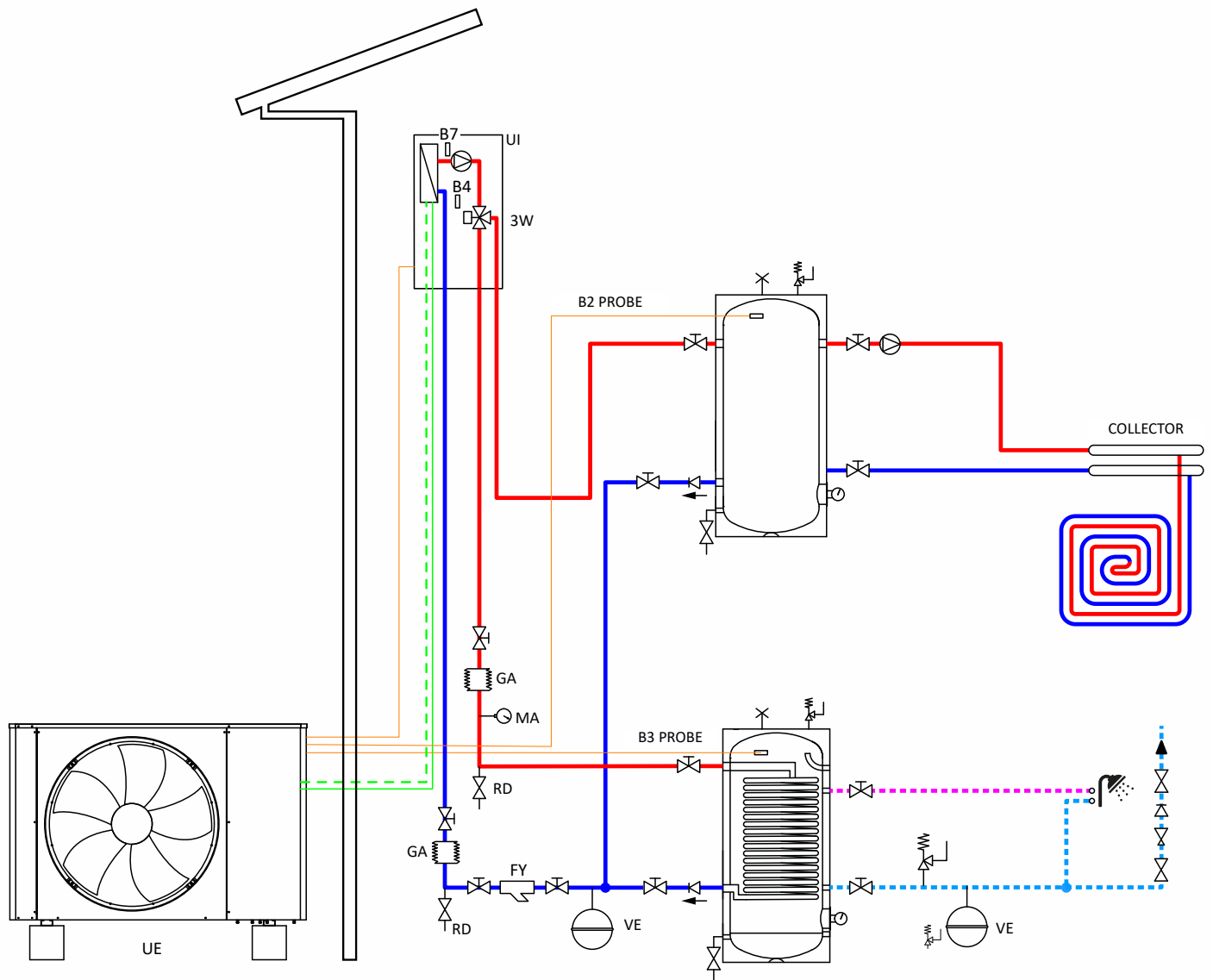

The following diagrams are purely an example and Templari s.r.l. will not be responsible for any reason for the plant made at home. The plant shall be designed and manufactured exclusively by qualified personnel.

9.5 Dyagram 1: heating and DHW system with puffer

- | | | | |
|----|----------------------|---|-----------------|
| GA | Anti-vibration joint | — | SIGNAL CABLES |
| MA | Manometer | — | OUT |
| RD | Drin tap | — | IN |
| 3W | 3 way valve | — | DHW |
| VE | expansion vessel | — | DW |
| FY | Y-filter | — | REFRIGERANT IN |
| UE | External unit | — | REFRIGERANT OUT |
| UI | Internal unit | | |



9.6 Dyagram 2: heating and DHW system with puffer and boiler backup

- | | | | |
|----|----------------------|---|-----------------|
| GA | Anti-vibration joint |  | SIGNAL CABLES |
| MA | Manometer |  | OUT |
| RD | Drin tap |  | IN |
| 3W | 3 way valve |  | DHW |
| VE | expansion vessel |  | DW |
| FY | Y-filter |  | REFRIGERANT IN |
| UE | External unit |  | REFRIGERANT OUT |
| UI | Internal unit | | |

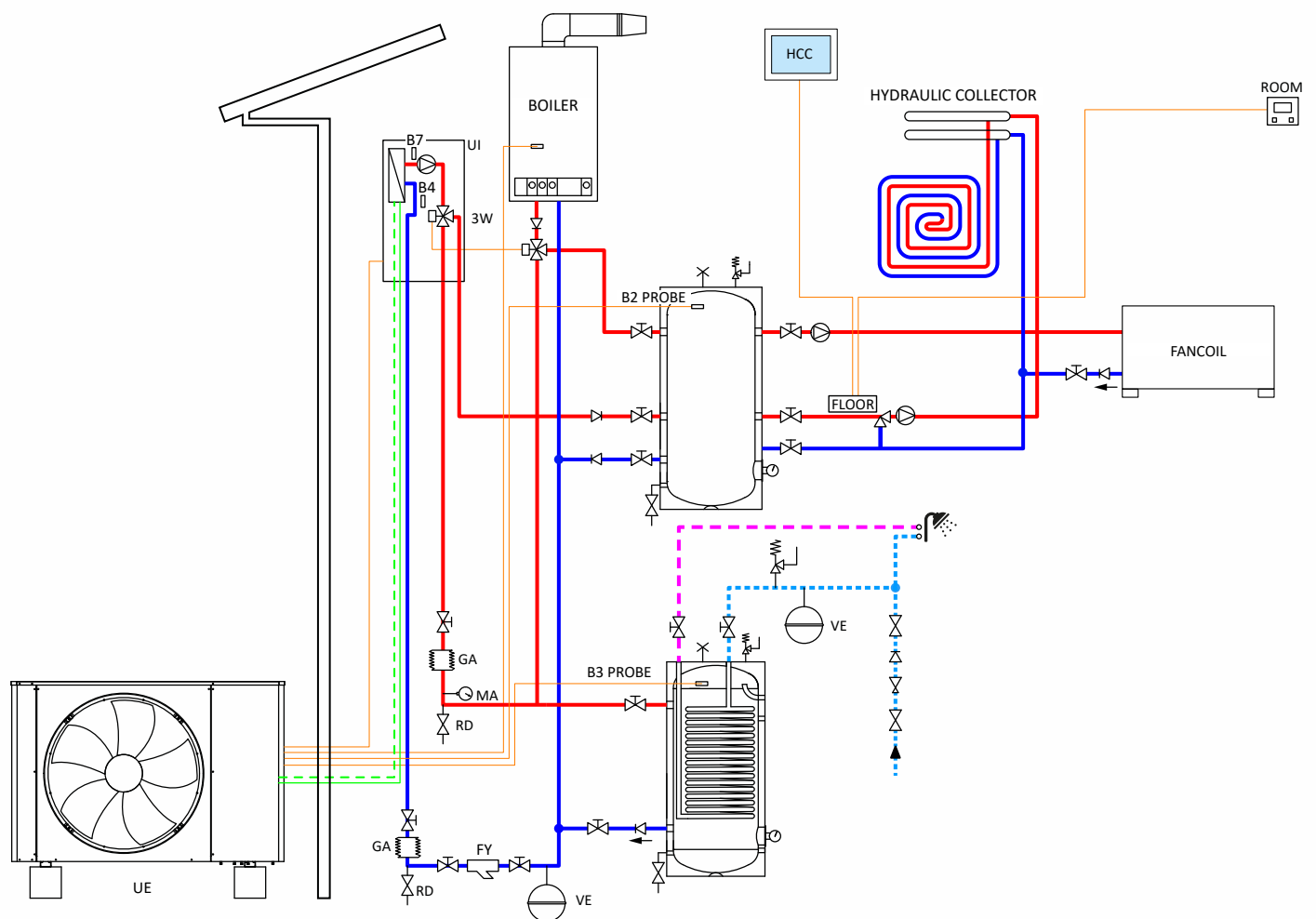

9.7 Dyagram 3: heating and dhw "t" system with instant DHW production plate exchanger kit

- | | | | |
|----|----------------------|---|-----------------|
| GA | Anti-vibration joint | — | SIGNAL CABLES |
| MA | Manometer | — | OUT |
| RD | Drin tap | — | IN |
| 3W | 3 way valve | — | DHW |
| VE | expansion vessel | — | DW |
| FY | Y-filter | — | REFRIGERANT IN |
| UE | External unit | — | REFRIGERANT OUT |
| UI | Internal unit | | |

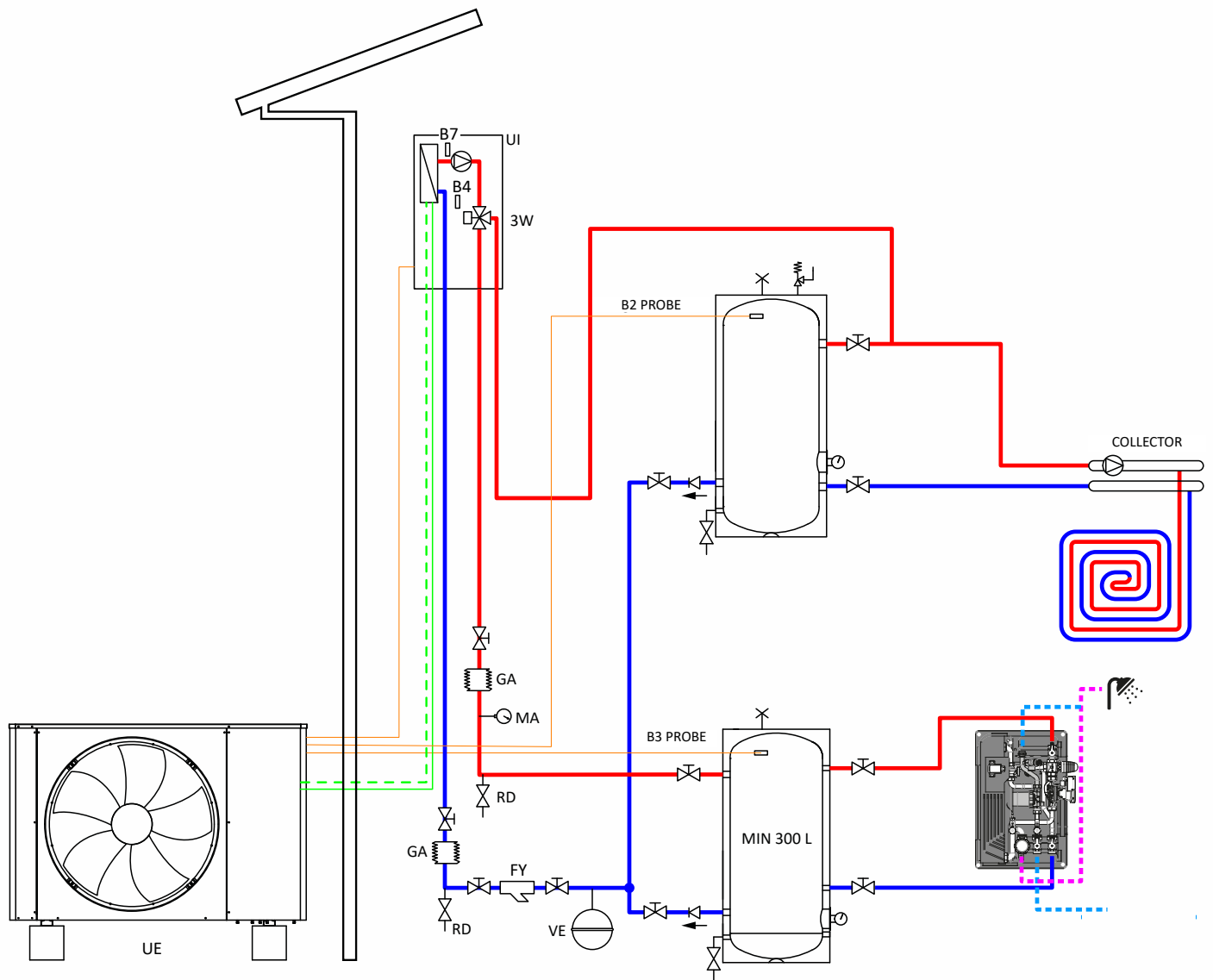





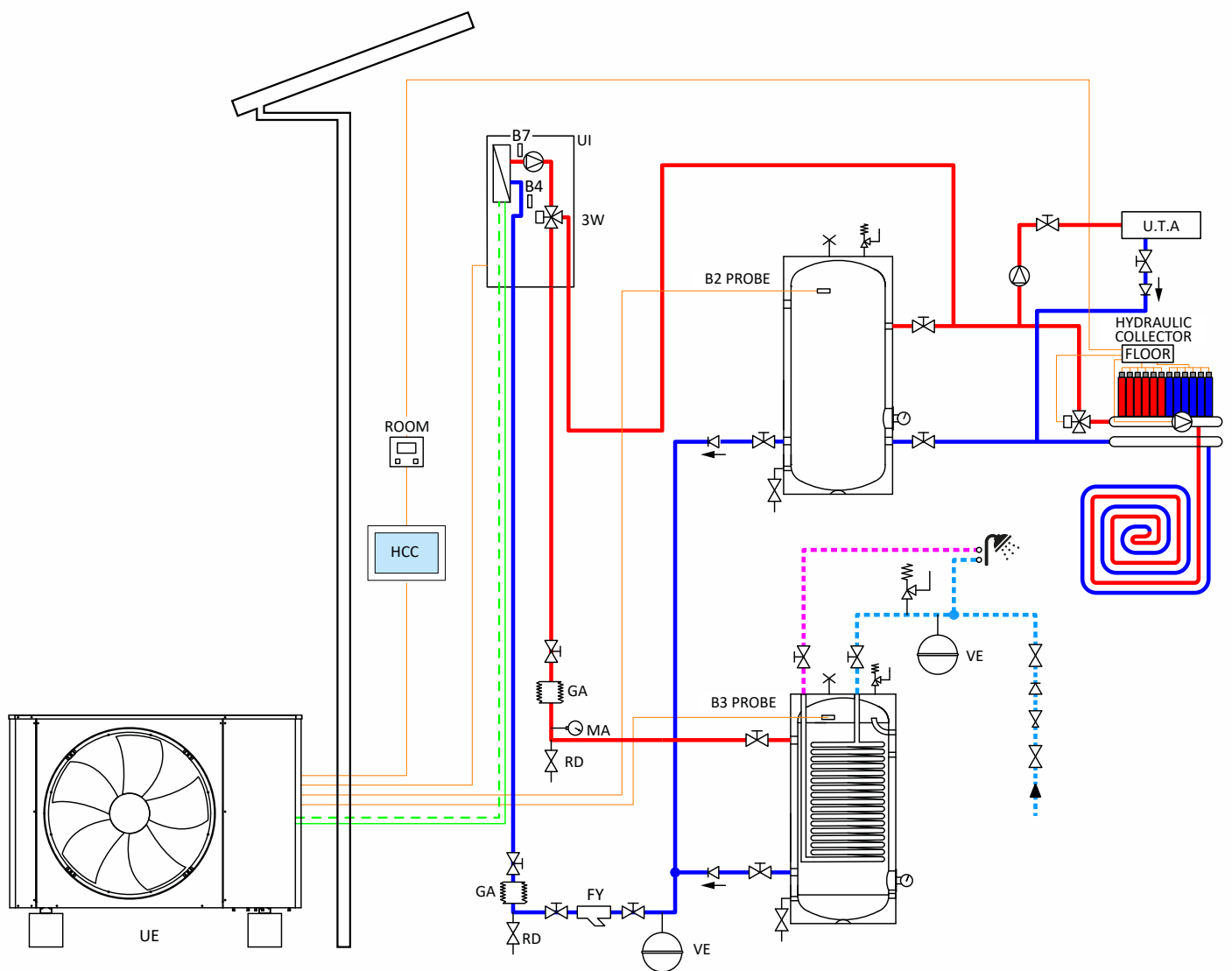

9.8 Dyagram 4: heating\cooling "t" system with air handling unit

- | | | | |
|----|----------------------|---|-----------------|
| GA | Anti-vibration joint | — | SIGNAL CABLES |
| MA | Manometer | — | OUT |
| RD | Drin tap | — | IN |
| 3W | 3 way valve | — | DHW |
| VE | expansion vessel | — | DW |
| FY | Y-filter | — | REFRIGERANT IN |
| UE | External unit | — | REFRIGERANT OUT |
| UI | Internal unit | — | |



9.9 Dyagram 5: heating\cooling and DHW "T" system

- | | | | |
|----|----------------------|---|-----------------|
| GA | Anti-vibration joint |  | SIGNAL CABLES |
| MA | Manometer |  | OUT |
| RD | Drin tap |  | IN |
| 3W | 3 way valve |  | DHW |
| VE | expansion vessel |  | DW |
| FY | Y-filter |  | REFRIGERANT IN |
| UE | External unit |  | REFRIGERANT OUT |
| UI | Internal unit | | |

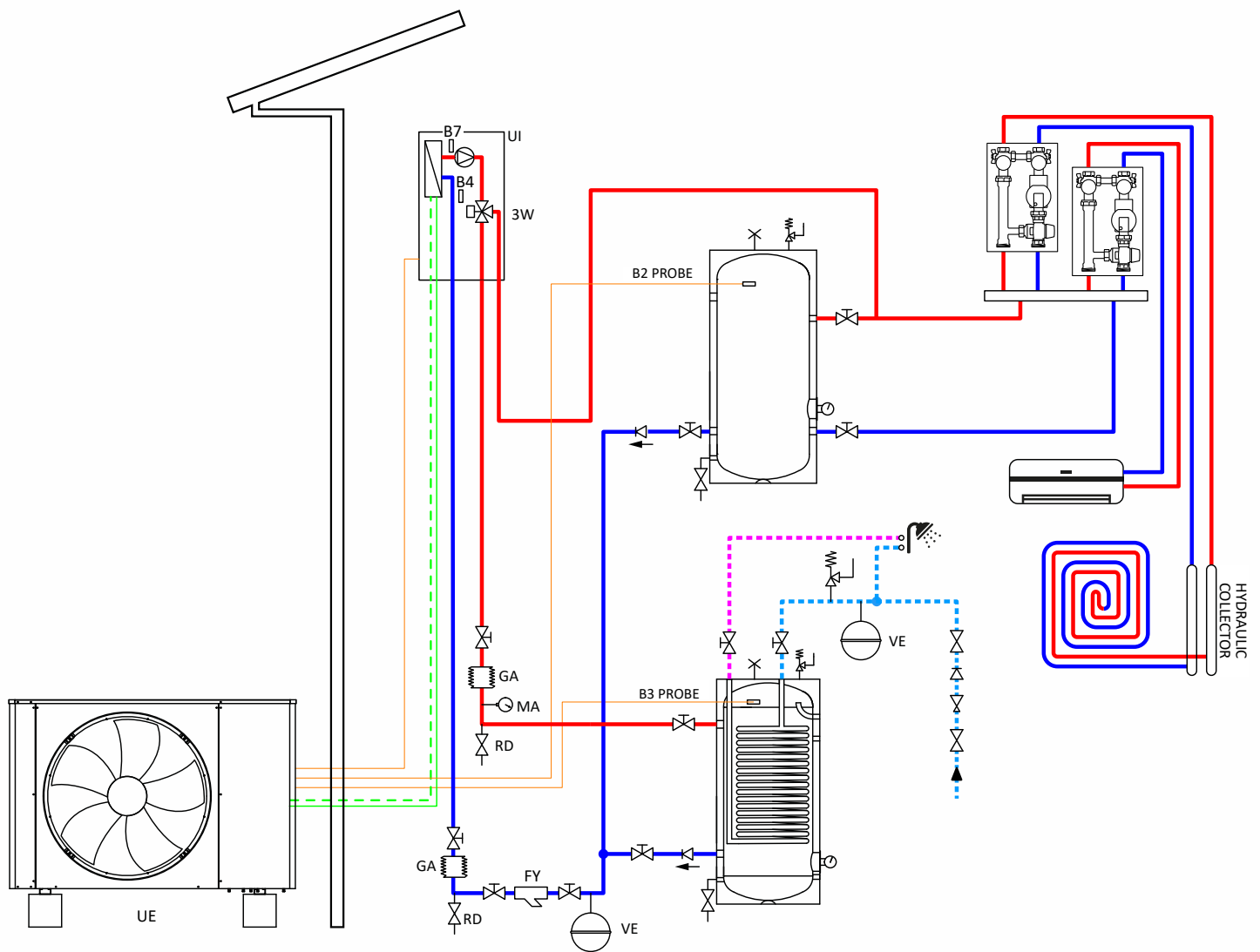

WARNINGS!

The buffer tank must always comply with a minimum quantity of liters according to the heat pump KITA used: KITA S 200 Liters, KITA M 300 Liters, KITA L 500 Liters

10 Maintenance and cleaning

A periodic maintenance is necessary in particular to keep a correct operation of the heat pump, to reduce the usury and the deterioration of the components.

The frequency of the intervention is decided by the user, and it depends on two factors:

- Mode of use: an annual maintenance is suggested, if the machine works in one mode (heat pump/chiller), or semiannual if the machine is used with both operation modes.
- Installation place: if the installation is made in places particularly subjects to pollution or particulate matter that could block the battery, it is suggested to properly monitor work conditions of the battery and, if necessary, provide to a more frequent maintenance.

⚠ WARNINGS!

Turn off the power to the machine before any maintenance intervention to avoid dangerous injuries caused by the activation of some operation systems of the machine.

10.1 Cleaning of the battery

During the operation of the machine it is possible that the coil finned is partially blocked by leaves or incrustations, causing also the malfunction of the heat pump. It is possible to clean the battery with a pressure air jet in parallel direction to the fins, it is also suitable to remove possible deposits in the battery compartment:

- Clean the front surface
- Remove the top panel as shown in figure

⚠ WARNINGS!

avoid the contact with the fins of the battery because you can cut.

Avoid to bend the fins of the battery because it reduces the performances of the machine. In case of bended fins, contact authorized service.

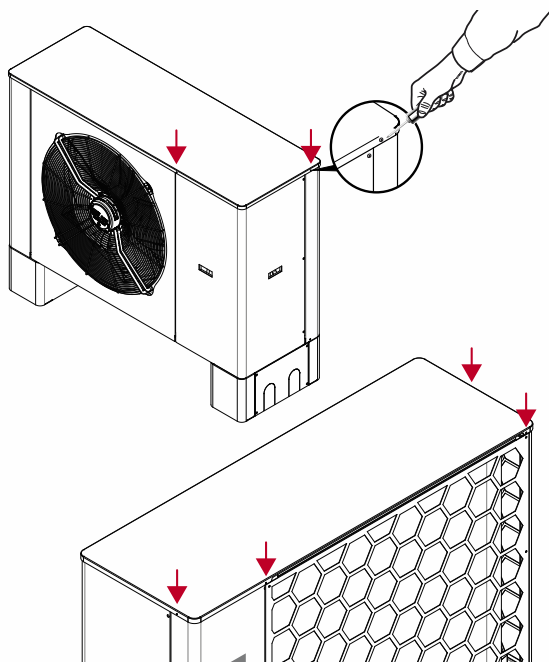

10.2 Cleaning of condensate drain

Make sure the condensate drain tube is in the correct position and not blocked, to allow the right condensate flow depositing on the battery during the operation of the heat pump.

10.3 Cleaning of hydraulic system side

Concerning the cleaning of the filter portare lead the hydraulic circuit to atmospheric pressure in corrispondance of impurities collector, remove unscrewing the seat and clean it.

Concerning the assembly follow the same steps in reverse order and make sure that the assembly of the filter is correct and the screwing is sealed.

Water recommended values

Parameters	Reference values
PH	6-8
Electrical conductivity	Less than 220 mV/cm (25°)
Chlorine ions	Less than 50 ppm
Sulfuric acid ions	Less than 50 ppm
Total iron	Less than 0,3 ppm
Alkalinity M	Less than 50 ppm
Total hardness	Less than 50 ppm (5°F)
Sulfur ions	none
Ammonia ions	none
Silicon ions	Less than 30 ppm

10.4 Cooling circuit maintenance

The machine is equipped with a security valve ensuring the reduction of the inside pressure to the cool circuit in case of outside heat generation (for example in case of fire). To ensure a correct operation of the valve, contact the manufacturer and make sure to replace it every 4 years.

⚠ WARNINGS!

The direct contact between the skin and the refrigerant outgoing from the security valve causes serious lesions. Don't pause near the valve.

11 Electrical connection

11.1 General information

- Before starting any operation adopt security devices, make sure the unit is in a stable balance and there aren't any tension elements nearby.
- Power line has to be equipped with protection devices able to stop the short-circuit current considering the situation of the machine.
- Make reference of the wiring diagram of the unit.
- The first connection is the grounding.
- Before powering the unit, all the line protections have to be enabled.

11.2 Laying operations

- Laying the cables at a certain distance from different tension lines or devices that can create electromagnetic interferences.
- Avoid the laying in parallel with other cables, only the 90° disposition is allowed.
- Pass the power cables and control network cable of the machine through the special holes (position 22) see the dimentions of the machines.

11.3 Power

OUTSIDE:

Connect the power to the terminal of the outside unit according to the table shown below "Power cables indications". The cable routing is made through the special cables .

INSIDE:

It is necessary to power the inside unit in one-phase (see the cables scheme at paragraph 12.1). For the type of cable make reference to the table "power cable indication"

WARNINGS!

The section of power cables is to be considered indicative and relative to the last part of the line towards the machine and it has to be as short as possible. Outside protection, the laying and the cable section of this power line have to be dimensioned and followed by an authorized staff and according to technical standards of national authorities.

Spend particular attention on the ground power connection that has to be the same between the two units. **ABSOLUTELY AVOID THE CONTACT BETWEEN THE SIGNAL GROUND (GND) AND GROUND POWER CONDUCTOR!**

Electrical details

MODEL	Power supply	Power at A-20 /W55	COP at A-20/W55	Electrical consumption A-20/W55 (kW)	INVERTER (A)	Thermal braker magnetic switch	Electrical differential switch (mA)	Cable section: 2mm (for a line with a total lenght up to 5 meters)
KITA Si	230V/1ph	5,58	1,99	2,80	18	16A	30mA	3x2,5
KITA Si Plus		6,31	1,75	3,60	18	20A	30mA	3x4
KITA Si Cold		9,10	1,77	5,14	18	30A	30mA	3x4
KITA Si Plus Cold		10,70	1,50	7,10	18	40A	30mA	3x4
KITA Mi		7,80	1,69	4,60	18	25A	30mA	3x4
KITA Mi Cold		11,80	1,47	8,00	18	40A	30mA	3x4
KITA Mi Plus		11,00	1,59	6,90	18	35A	30mA	3x4
KITA Mi Plus Cold		16,70	1,89	8,84	18	50A	30mA	3x4
KITA Si	400V/3ph	5,58	1,99	2,80	18	16A	30mA	5x2,5
KITA Si Plus		6,31	1,75	3,60	18	16A	30mA	5x4
KITA Si Cold		9,10	1,77	5,14	18	16A	30mA	5x4
KITA Si Plus Cold		10,70	1,50	7,10	18	16A	30mA	5x4
KITA Mi		7,80	1,69	4,60	18	20A	30mA	5x4
KITA Mi Cold		11,80	1,47	8,00	18	20A	30mA	5x4
KITA Mi Plus		11,00	1,59	6,90	18	20A	30mA	5x4
KITA Mi Plus Cold		16,70	1,89	8,84	18	20A	30mA	5x4
KITA L33	400V/3ph	23,10	2,37	9,75	18	20A	30mA	5x4
KITA L42		28,80	2,69	10,71	24	32A	30mA	5x6
KITA L66		18,30	1,46	12,50	24	32A	30mA	5x6
KITA L Cold		29,70	1,48	20,00	35	40A	30mA	5x6
KITA Li Plus		33,20	1,65	20,12	40	40A	30mA	5x6

11.4 Outside unit connection

Besides the power mentioned in previous paragraphe it is necessary to provide to the outside unit the following connections too:

- Connect the temperature probes B2 and B3 (B3 only in case of domestic management) (see terminal teble at paragraphe 12.2)
Probes supplied by the parent company (in case of extension cord use the 1,5 mmQ multipolar cable shielded following the shortest route and far from the power cable. Spend particular attention on the connections since the possible parasitic resistances affect the reading).
- If there is a boiler/additional resistance, connect it to the relay in the board. The relay has a common contact exchanging NA-NC.
- If there is a flowmeter (KITA Energy) consult the electrical schemes 13.5, 13.6, 13.7 (B5 = clamp 37)

11.5 Connection between indoor and outdoor unit

- Use a 4 wires cable 1,5 mmq shielded for the connection of:
 - Flow switch
 - Return proble B4
 - Flow probe B7
 - GND commmon
 the cable carries low voltage control signals: look for a route far from possible sources of trouble, don't make joints along the way.
- Use a 2 wires section 1,5 mmq multipolar cable to connect the circulator. In case of circulator management with modulation PWM provide another cable to connect to the special clamp.

11.6 Connection of the remote panel

The panel can be fixed:

- directly on the wall through the screws and the fischer supplied with the kit (optional version supplied on demand).

To fix the panel proceed as shown:

- fix the back box (A) to the standard box or to the wall (Pic. 2);
- connect the phone cable to the panel;
- fix the front (B) to the back box (A) by the screws supplied with the kit;
- instal the snapframe (C).

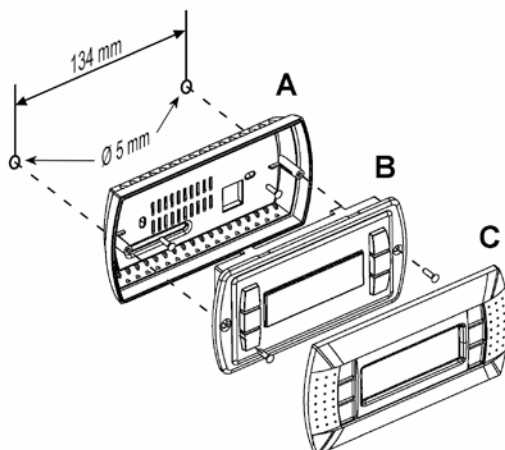

For the K-Touch connection see section 15

12 Terminal wiring

12.1 Indoor unit connectors wiring

The following schemes are valid for all Kita Split models:

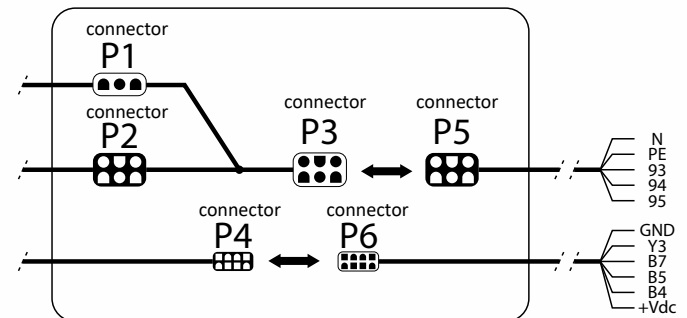

Connect P3 connector with P5 and P4 connector with P6.

Connect the end of P5 connector to relays K1/K2 to the power terminal board in the outdoor unit.

Connect the cables at the end of P6 to the respective connectors on the μ Pc.

Connections description:

Connector	Inside unit
P1	Circulator
P2	3 way valve
P3	Connettore verso unit� esterna.
P4	Probes
	Outside unit
P5	Power supply
P6	Probes

12.2 Terminal wiring outdoor unit

The following scheme is valid for all Kita Split model:

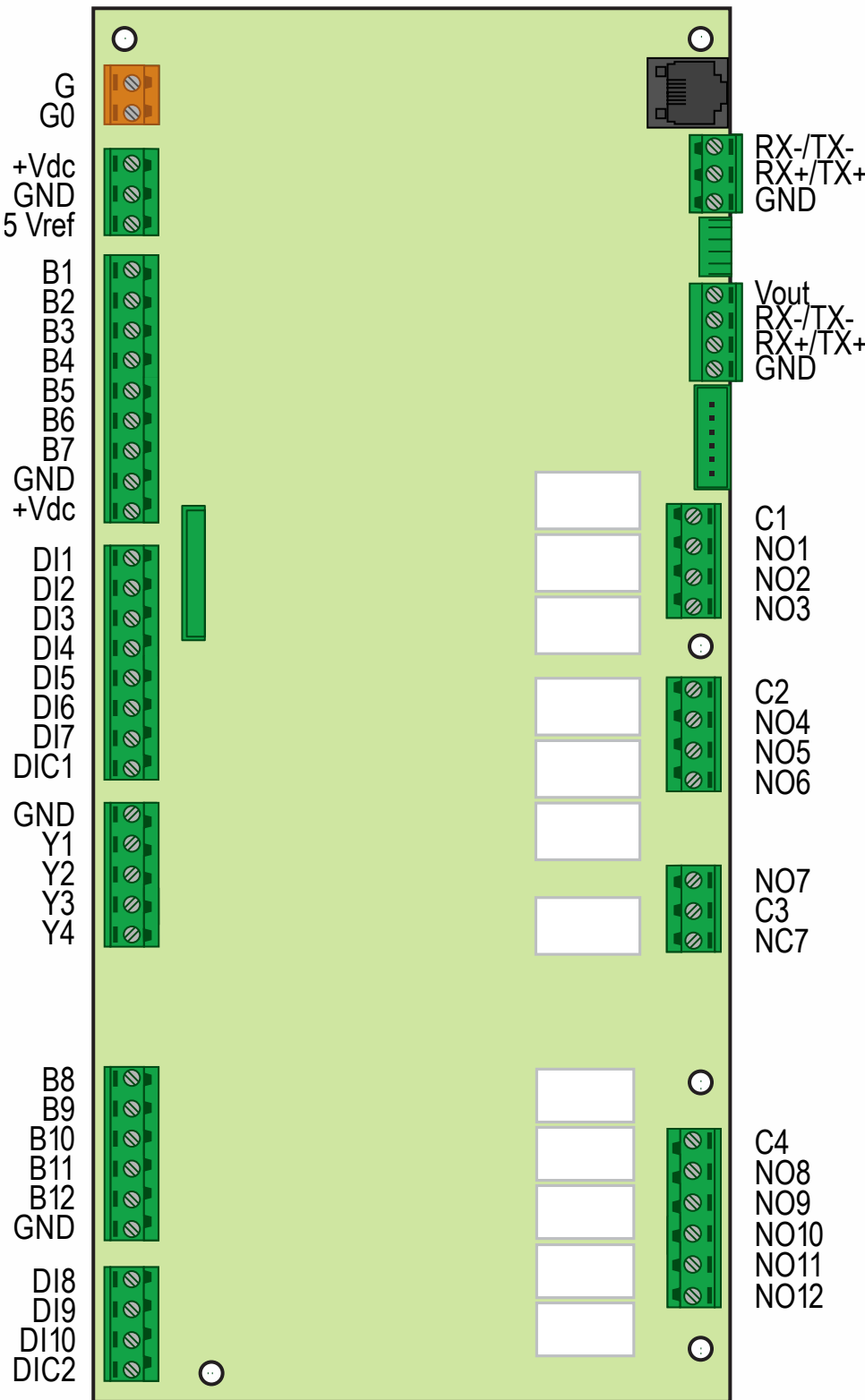

Connector description:

B1	Subcooling
B2	Radiant probe
B3	Domestic probe
B4	Return probe
B5	Flow meter
B6	Head compressor probe
B7	Flow probe
B8	External temperature probe
B9	Drain probe
B10	Suction probe
B11	High pressure transducer
B12	Low pressure transducer
DI1	Summer-winter switch
DI2	Thermal sensor
DI3	High pressure switch
DI4	/
DI5	Disable plant
DI6	Photovoltaic inverter overproduction contact
DI7	System auxiliary heater security
DI8	Remote on-off
DI9	Switch modbus controller
DI10	Flow switch
Y1	/
Y2	Internal fan KITA Air
Y3	PWM circulator
Y4	External fan KITA Air
NO1	Integration
NO2	Defrost
NO3	Air-air or air-water indicator
NO4	Circulation pump
NO5	Condensate drain heating
NO6	Plant integration demand
NO7	General alarm
NO8	DHW integration demand
NO9	3-way valve
NO10	4-way valve
NO11	Oil heating
NO12	Desuperheater

12.3 Version 1: Terminal wiring for KITA with circulator and Relay K2 only

The terminal board is equipped with a single relay (K2) that manages the circulator.
Refer to the table in 12.2 for standard connections.

Relay K2	CIRCULATOR MANAGEMENT
A1	Relay coil
A2	Relay coil
14	Normally open contact (Na)
12	Normally close contact (Nc)
11	Common contact (C)

Probe B2 should be connected to the pre-wired cable provided with the heat pump.

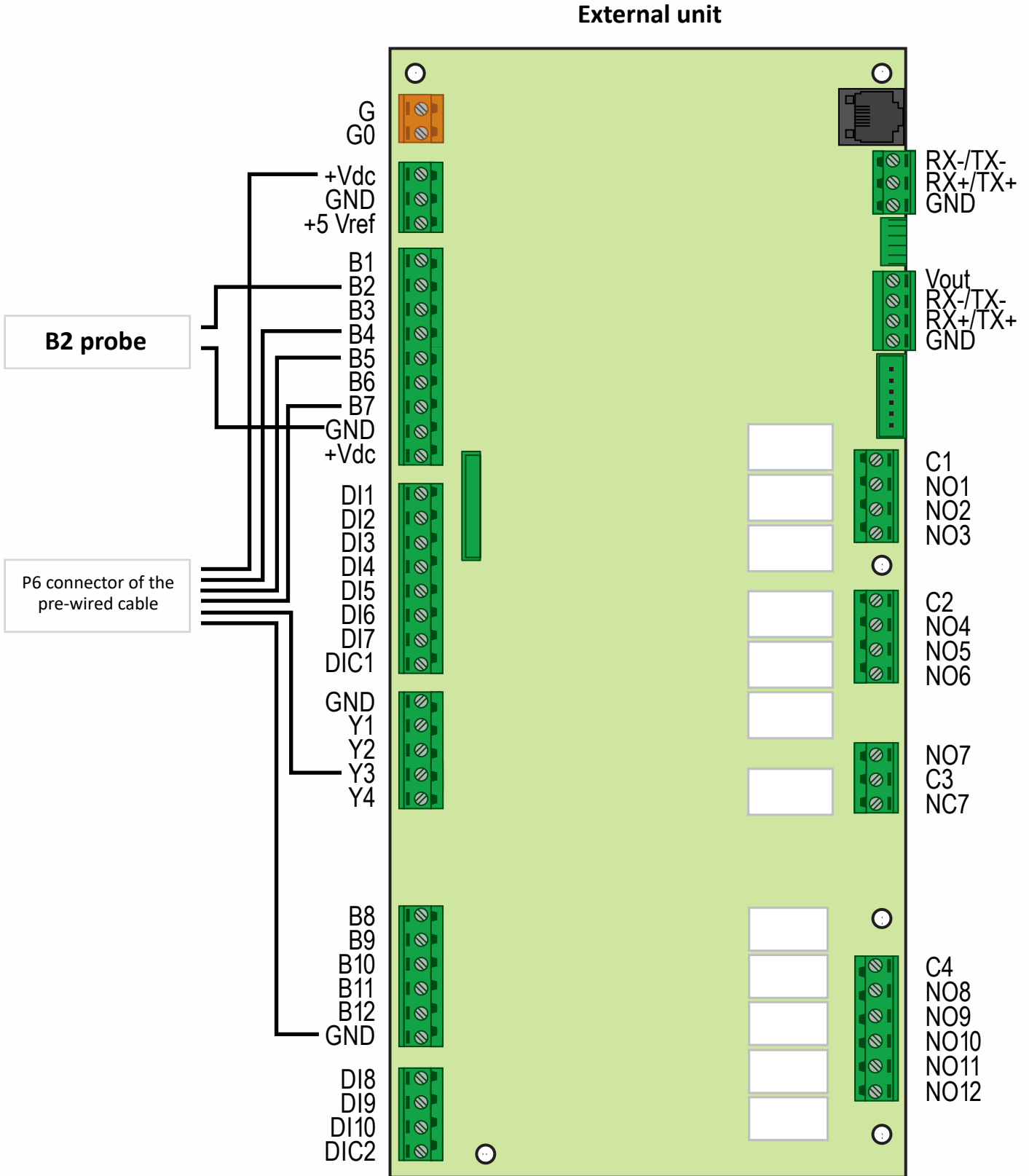

Single-phase model version 1

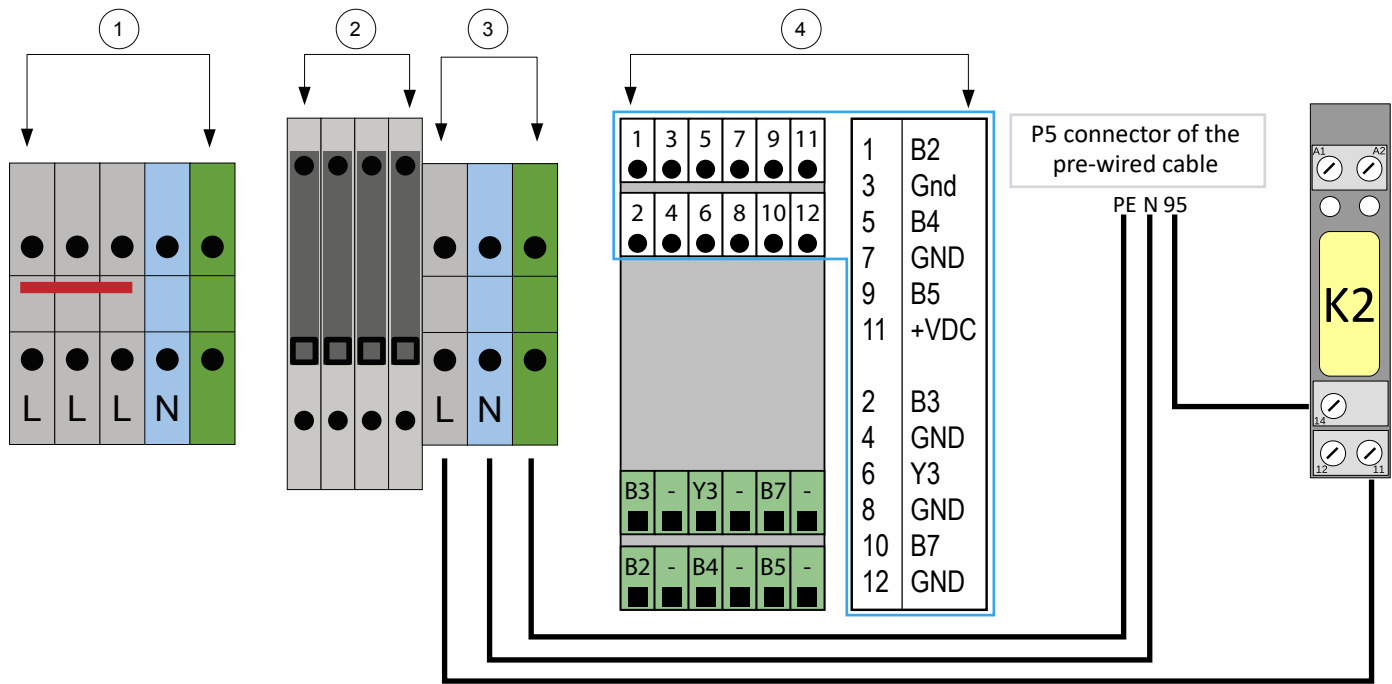

1 Power: power terminal
2 Auxiliary fuses 4 A

3 Power: Phase, Neutral and Ground for internal split
4 Sensor terminal block (the symbol - indicates GND)

Three-phase model version 1

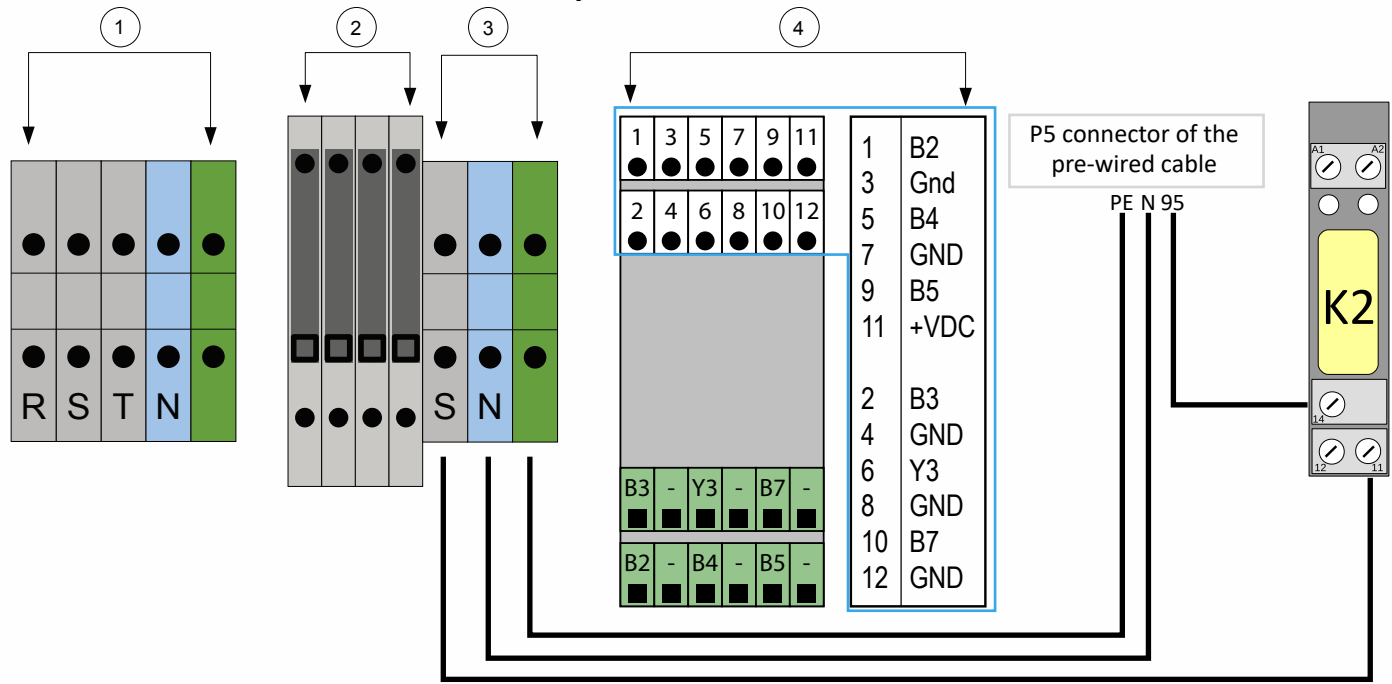

1 Power: power terminal
2 Auxiliary fuses 4 A

3 Power: Phase, Neutral and Ground for internal split
4 Sensor terminal block (the symbol - indicates GND)

External unit

Internal unit

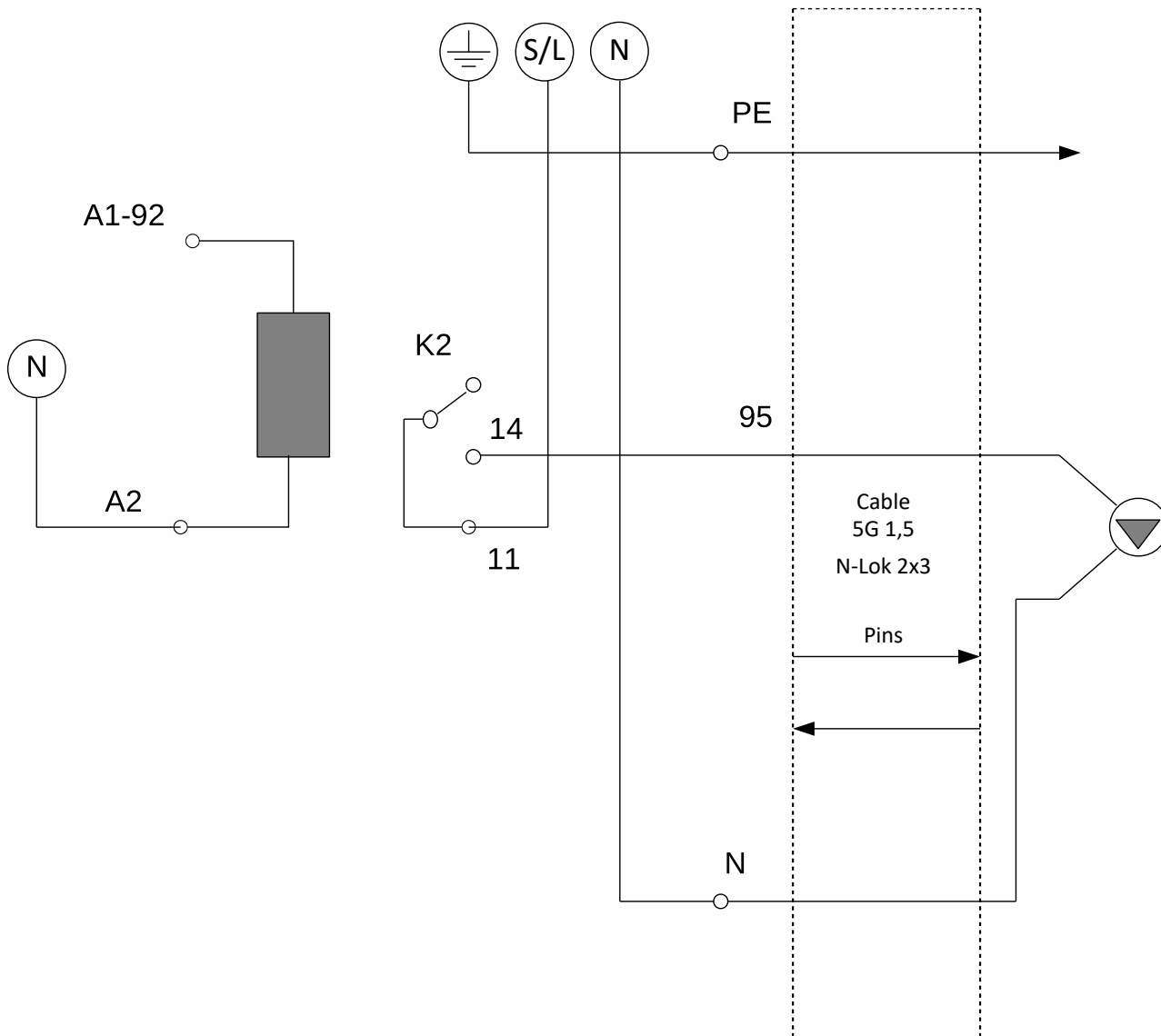

A1-92 K2 NO4 μ PC
 A2 K2 Neutral external unit
 11 K2 S/L Phase* external unit

95 Circulator phase
 N Neutral external unit

*S 3-phase version, L monophase version

12.4 Version 2: One relay for circulator management and one for DHW management with Templari - de pala 3-way valve

If you want to manage a 3-way valve Templari (preassembled or supplied separately) for the domestic management, the terminal has the relay K1 fit for this management.

The relay K2 manage the circulator.

Refer to the table in 12.2 for standard connections.

The probes B2 and B3 must be connected to the **pre-wired cable** provided with the heat pump.

External unit

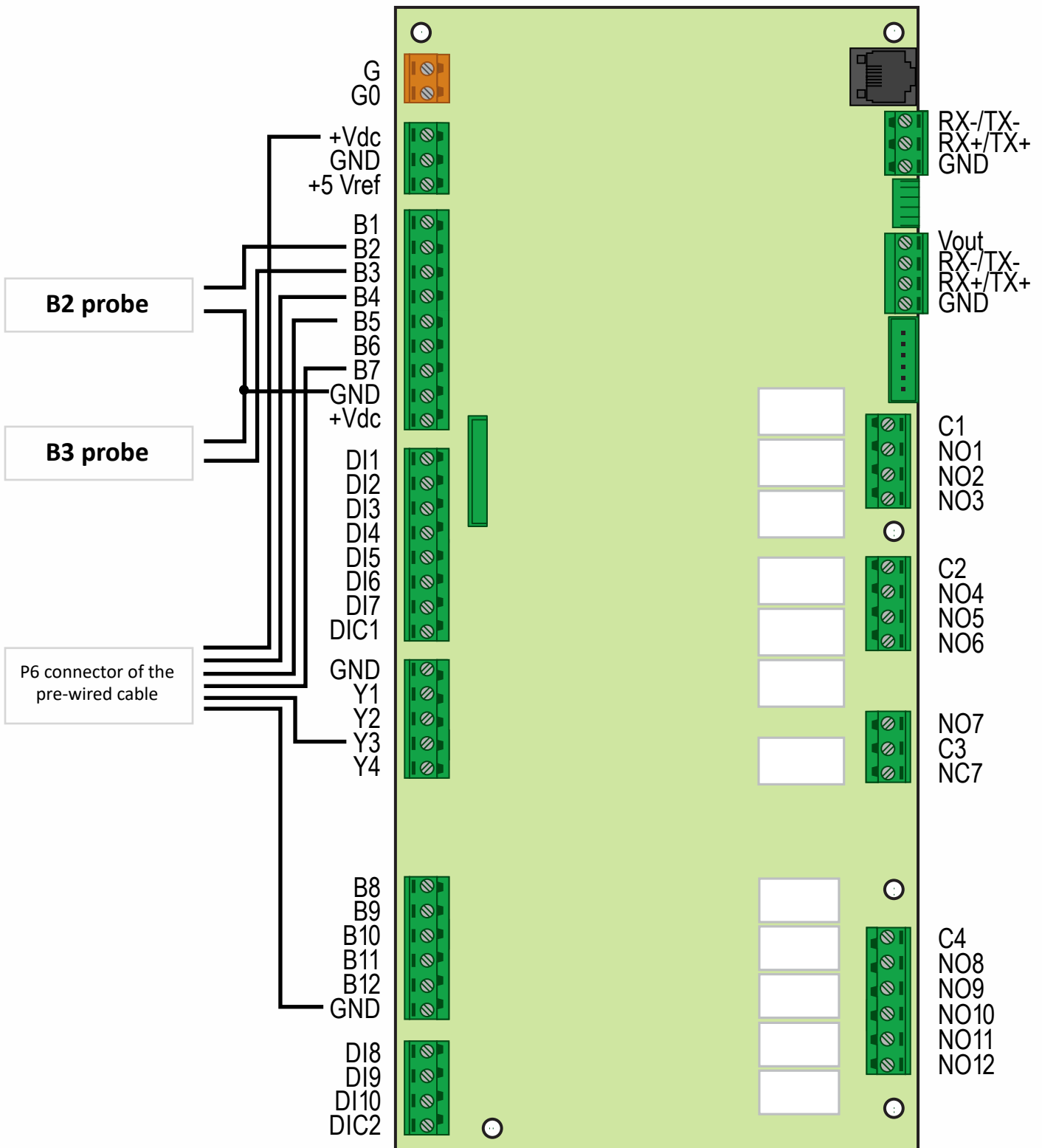

Single-phase model version 2

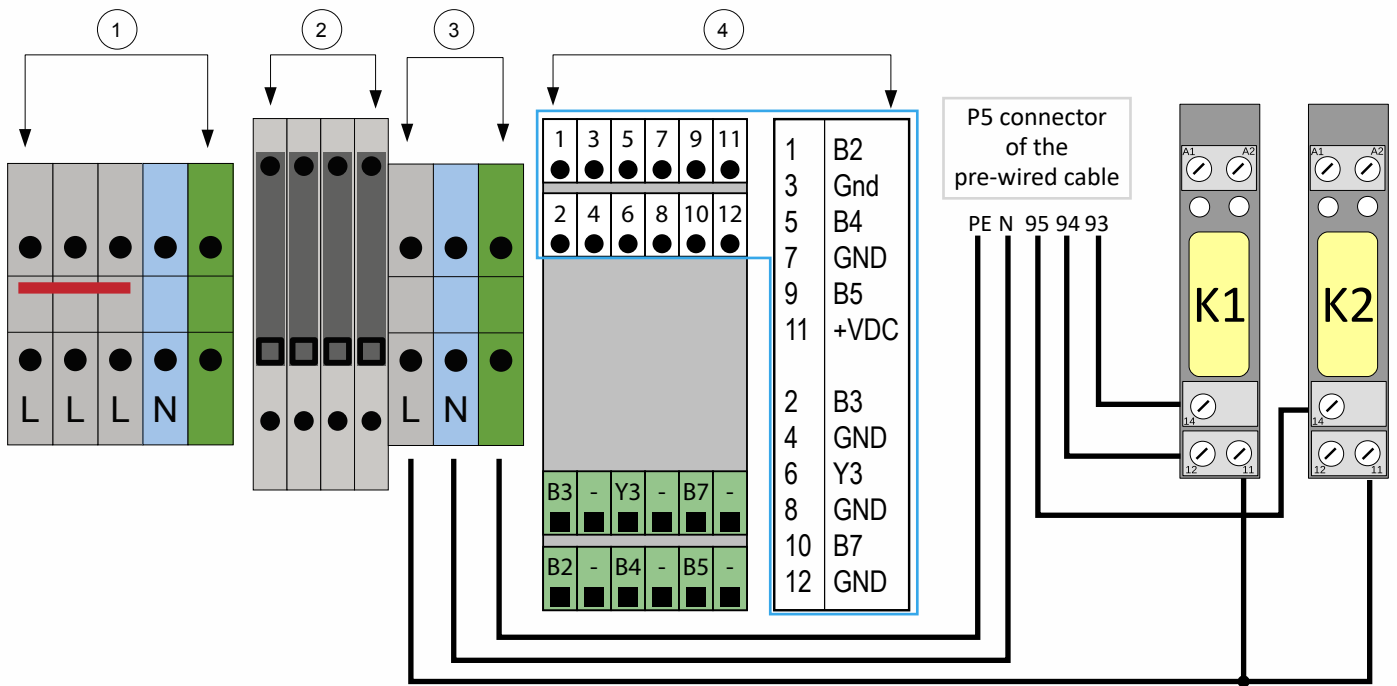

- 1 Power: power terminal
- 2 Auxiliary fuses 4 A
- 3 Power: Phase, Neutral and Ground for internal split
- 4 Sensor terminal block (the symbol - indicates GND)

Three-phase models version 2

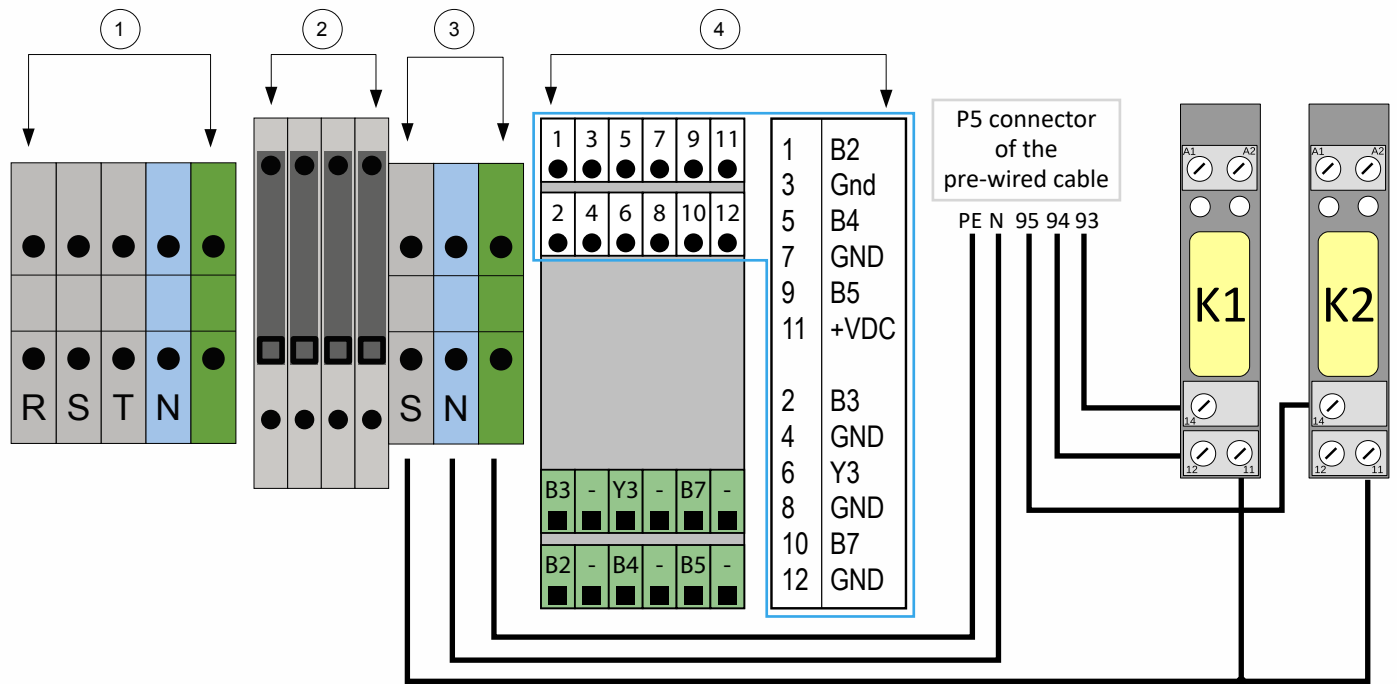

- 1 Power: power terminal
- 2 Auxiliary fuses 4 A
- 3 Power: Phase, Neutral and Ground for internal split
- 4 Sensor terminal block (the symbol - indicates GND)

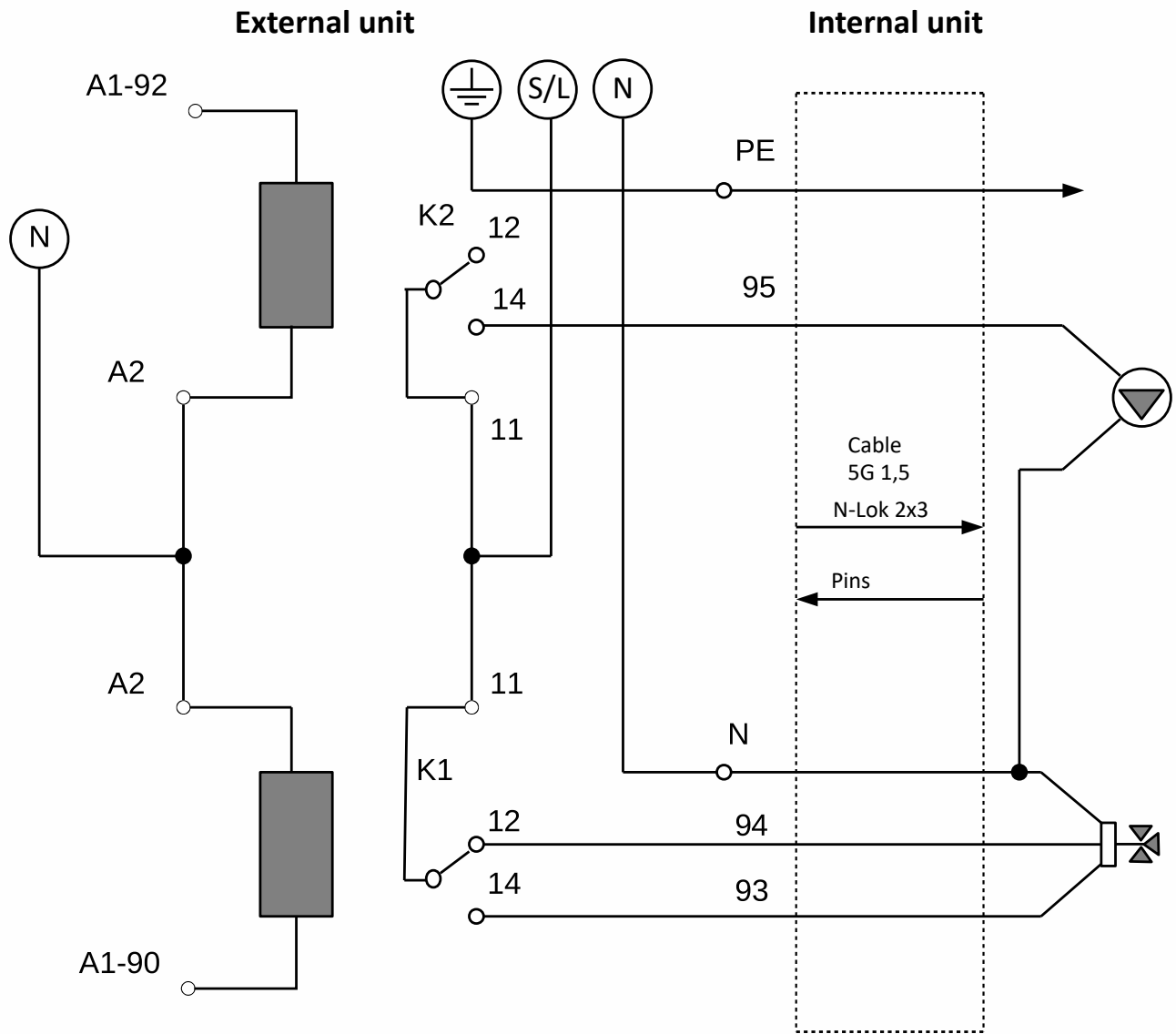

A1-90 K1 NO9 μ PC
 A2 K1 Neutral external unit
 A1-92 K2 NO4 μ PC
 A2 K2 Neutral external unit
 11 K1 S/L Phase* external unit
 11 K2 S/L Phase* external unit
 **S 3-phase version, L monophas version

94 3 way phase close
 93 3 way phase close
 95 Circulator phase
 N Neutral external unit

3 way:
 Brown = Phase open Blue = Phase close
 Black = Neutral Y/G = Ground

K1 Relay	DHW MANAGEMENT
A1	Relay coil to NO9 uPC contact
A2	Relay coil to Neutral external unit
14	Normally open contact (NO)
12	Normally closed contact (NC)
11	Common contact (C)

K2 Relay	CIRCULATOR MANAGEMENT
A1	Relay coil to NO4 uPC contact
A2	Relay coil to Neutral external unit
14	Normally open contact (NO)
12	Normally closed contact (NC)
11	Common contact (C)

12.5 Version 3: One relay for circulator management, one relay for DHW management, one relay for additional integration

If in the previous version (2) it is necessary to manage both the auxiliary integration and the DHW, another K3 relay will be added in the omega bar.

Make reference to the table in paragraph 12.2 of the complete manual for standard connections.

Make reference to the scheme of version 2 for K1 and K2 connections.

The table with the contact to connect the K3 relay is shown below.

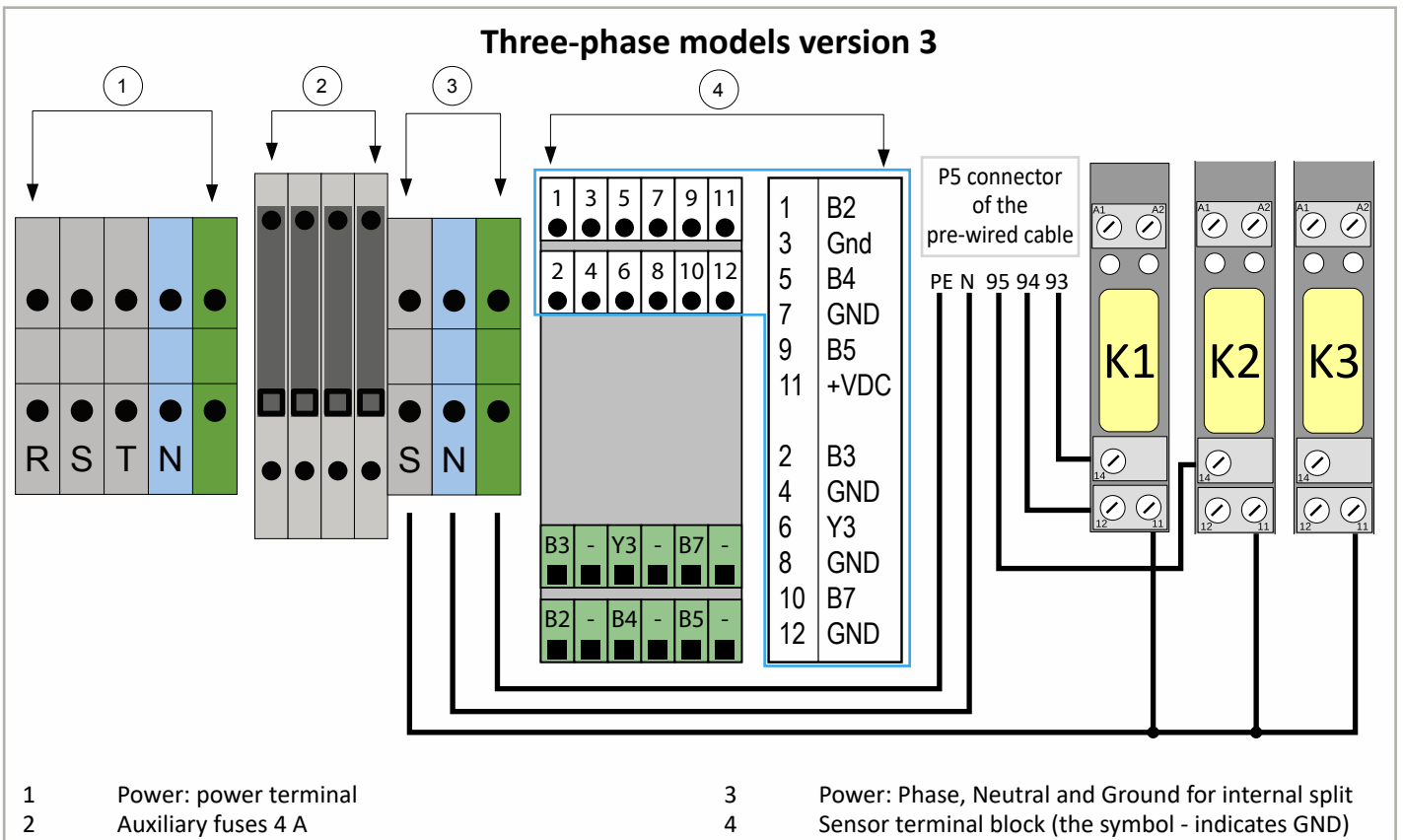
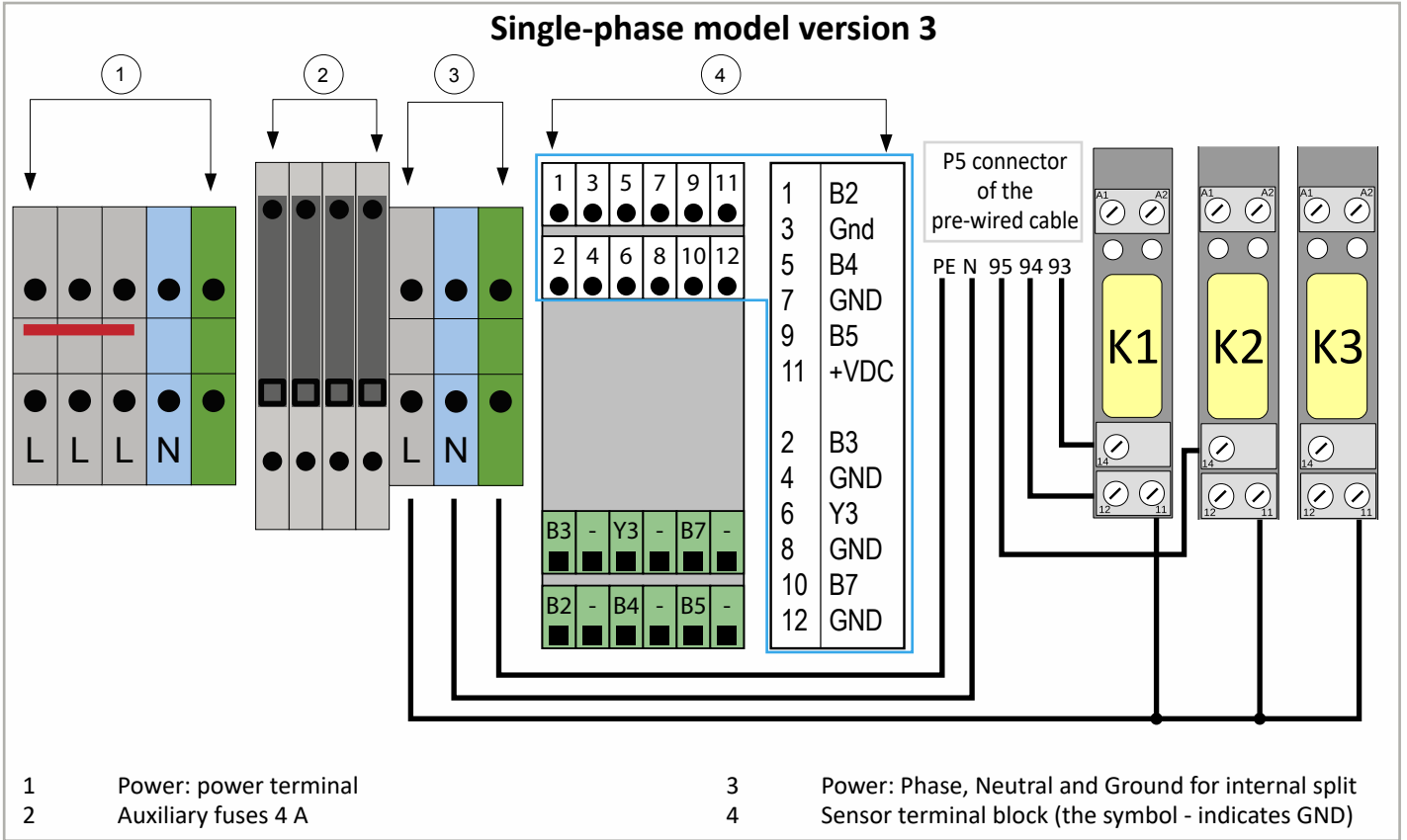

External unit

Internal unit

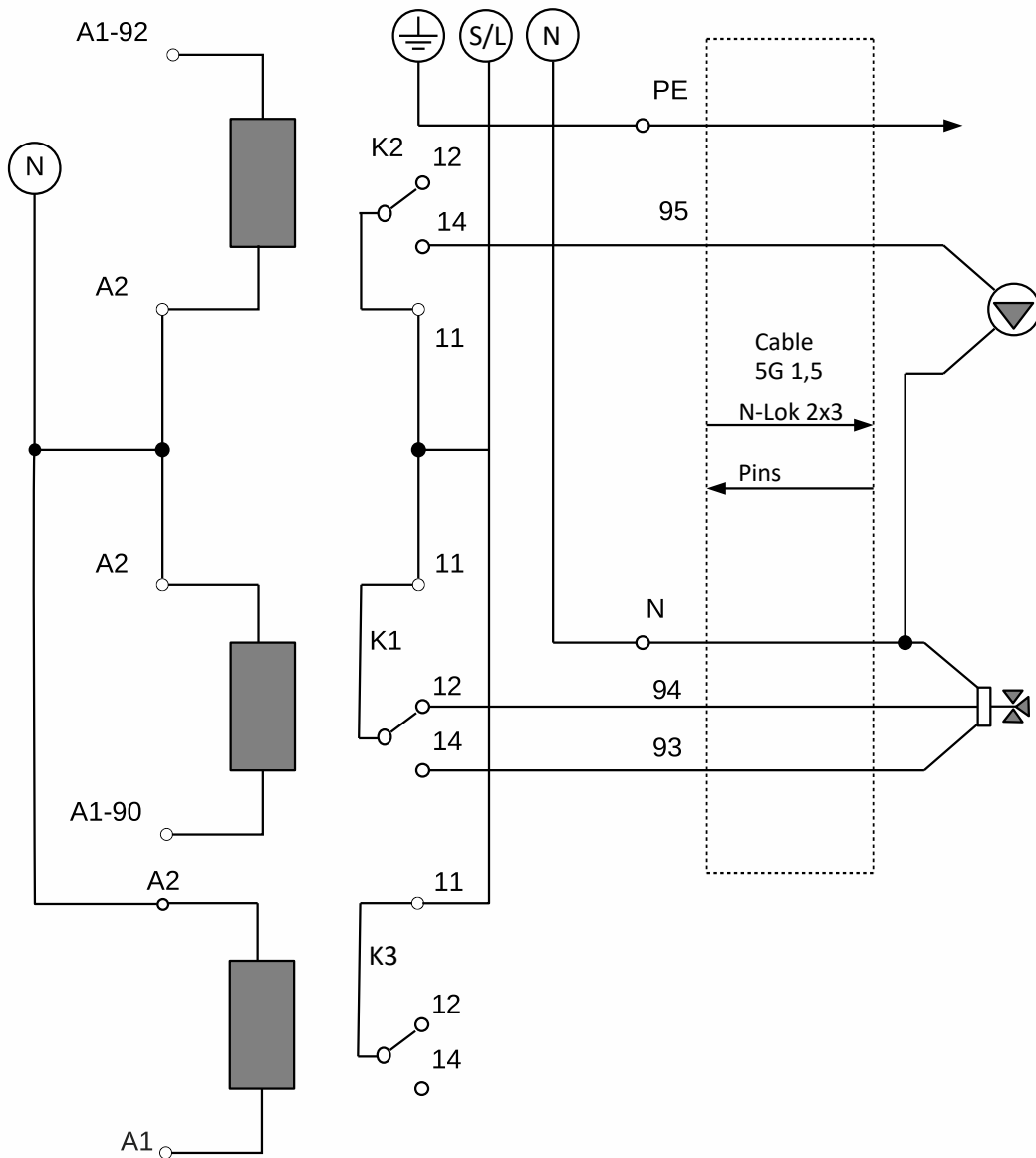

- A1-90 K1 NO9 μPC
- A2 K1 Neutral external unit
- A1-92 K2 NO4 μPC
- A2 K2 Neutral external unit
- 11 K1 S/L Phase* external unit
- 11 K2 S/L Phase* external unit

- A1 K3 NO6 μPC
- A2 K3 Neutral external unit
- 11 K3 S/L Phase* external unit

- 94 3 way phase close
- 93 3 way phase open
- 95 Circulator phase
- N Neutral external unit

3 way:
 Brown = Phase open
 Black = Neutral
 Blue = Phase close
 Y/G = Ground

*S 3-phase version, L monophase version

K1 Relay	DHW MANAGEMENT
A1	Relay coil to NO9 uPC contact
A2	Relay coil to Neutral external unit
14	Normally open contact (NO)
12	Normally closed contact (NC)
11	Common contact (C)

K3 Relay	INTEGRATION MANAGEMENT
A1	Relay coil to NO6 uPC contact
A2	Relay coil to Neutral external unit
14	Normally open contact (NO)
12	Normally closed contact (NC)
11	Common contact (C)

K2 Relay	CIRCULATOR MANAGEMENT
A1	Relay coil to NO4 uPC contact
A2	Relay coil to Neutral external unit
14	Normally open contact (NO)
12	Normally closed contact (NC)
11	Common contact (C)

12.6 9 KW Kita auxiliary heating element

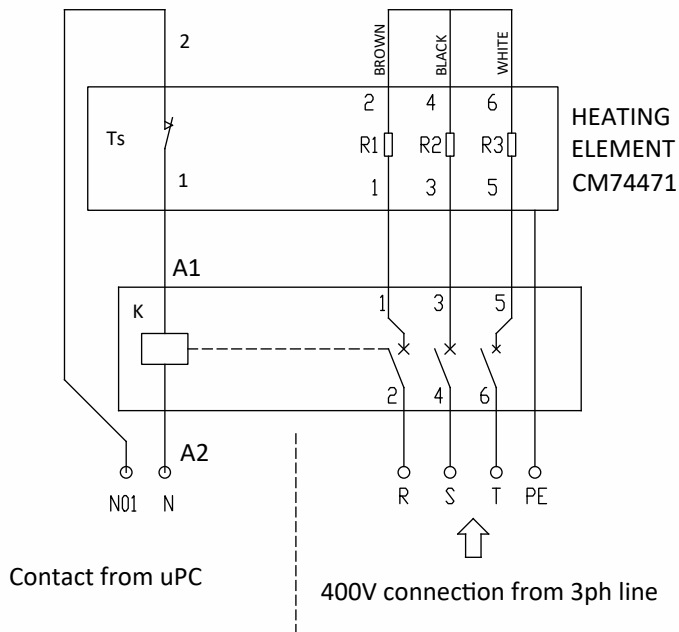

K= contactor 400 Vac 25A 3 poles 230 Vac
Bring phase (S) to (C1) uPC, coil activation to N01

Management of the auxiliary heating element installed in the outlet pipe

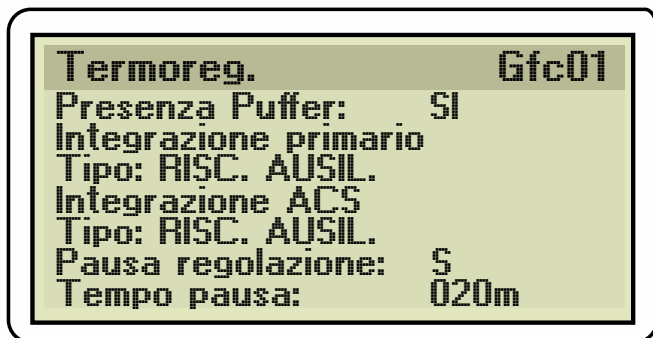

Line 4: select system integration mode

Line 6: select DHW integration mode

The heating element installed in the outlet pipe. before the 3 way valve allows to manage the integration for both the system and the DHW (*).

To activate the integration go to Gfc01 mask of the service menu and enable the system auxiliary heating option.

For further regulations check the paragraph "service menu".

For the electric connection follow the diagram 12.6 (Kita auxiliary heating element 9 KW).

⚠ WARNING!

(*) It is not possible to use the Kita auxiliary heating element for the antilegionella cycle.

12.7 TSplit description

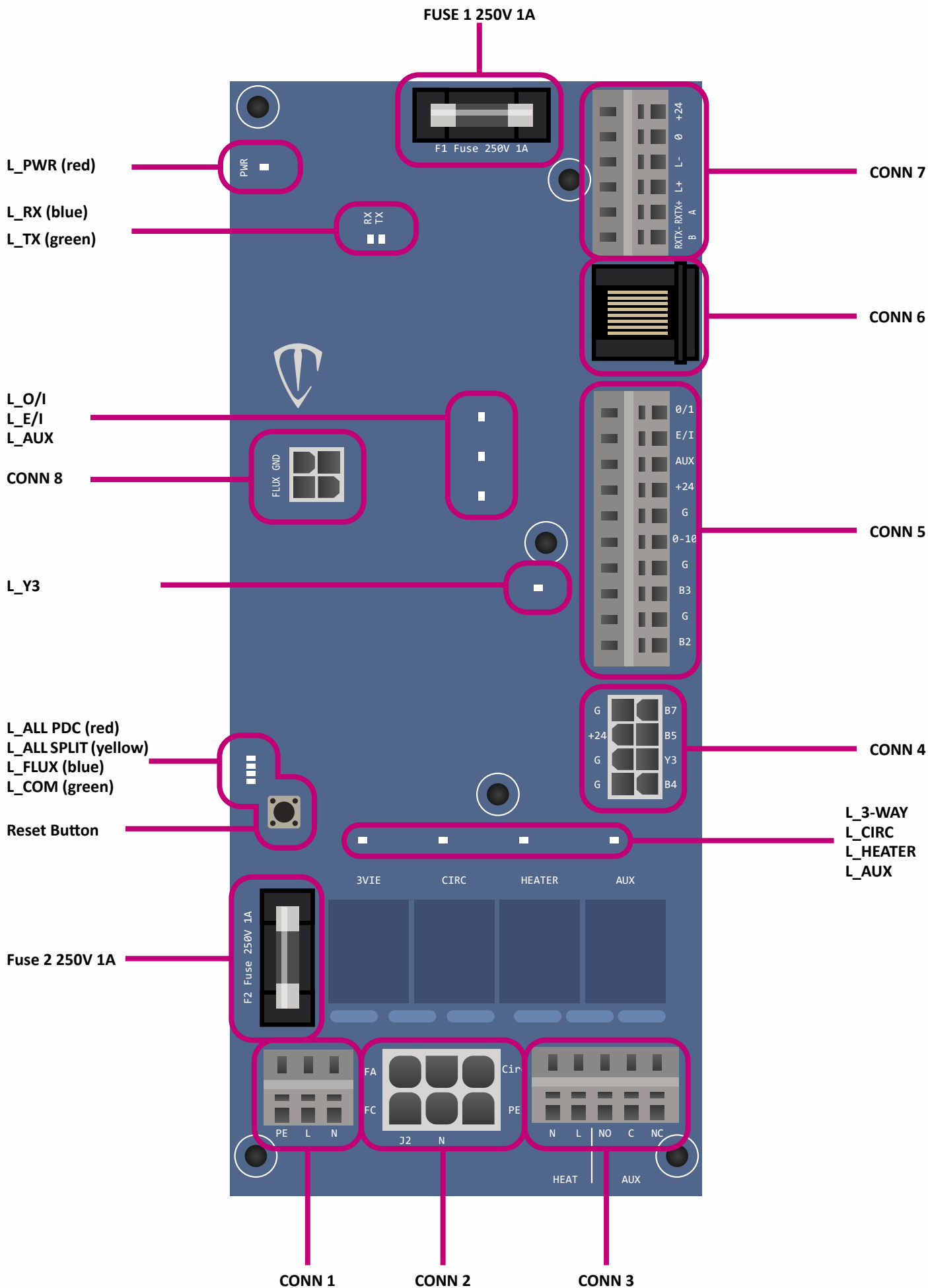

CONN 1

split power input connector, 230 VAC.



Pic.1

PE: ground pole
L: phase pole
N: neutral pole

CONN 2

3 way valve and circulator connector.

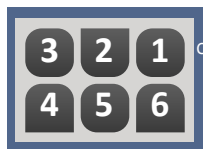

Pic.2

1: circulator power input phase
2: NC
3: 3 way: phase OPEN
4: ground connection
5: 3 way: phase CLOSE
6: neutral pole

CONN 3

Main connector for contactor terminals and auxiliary relay.

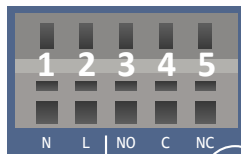

Pic.3

1: contactor neutral pole A2, 230 VAC
2: contactor phase pole A1, 230 V
3: normally open contact auxiliary relay
4: common contact, auxiliary relay
5: normally closed contact, auxiliary relay

CONN 4

connector for B4, B7, B5, Y3 probes.

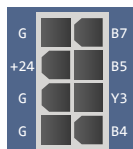

Pic.4

CONN 5

main connector for digital inputs 0-10 V inputs, B2 and B3 probes.

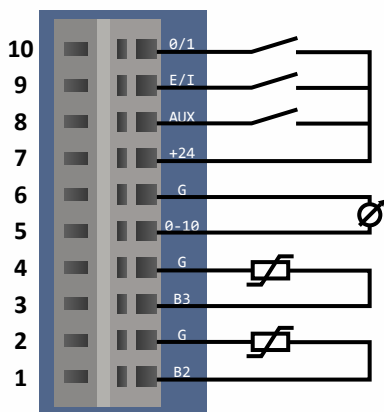

Pic.5

Pin	Function	Functioning	
		Open contact	Closed contact
10	heat pump remote OFF	Disabled	Enabled
9	heating/cooling	Heating	Cooling
8	Plant Aware	Enabled	Disabled
7	Auxiliary power input +24 V		
6	Ground		
5	0-10V input		
4	Ground		
3	B3 DHW temperature probe		
2	Ground		
1	B2 temperature probe		

CONN 6

main connector for RJ45 (HP/split communication) and 24 VDC power input.

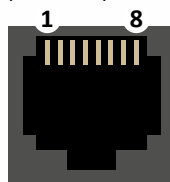

Pic.6a

1 - RXTX +, Fieldbus +, A
2 - RXTX -, Fieldbus -, B
3 - L+, BUS +
4 - +24VDC
5 - +24VDC
6 - L -, BUS -
7 - GND
8 - GND

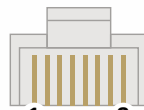

Pic.6b



Pic.6c

CONN 7

Auxiliary connector for communication and power input.

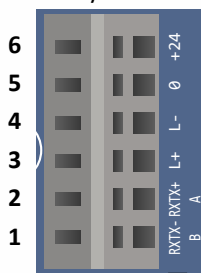

Pic.7

1 - RXTX -
2 - RXTX +
3 - L+
4 - L-
5 - GND
6 - +24VDC

CONN 8

Impulsive flow meter connector.



Pic.8

1 - GND
2 - /
3 - +5VDC
4 - impulsive contact

RESET BUTTON

Pressing the button a reset of the split board FW will be carried out. This will cause a "communication failure" between the heat pump and the split board and therefore an alarm due to the communication hole.

LIGHTS DESCRIPTIONS

L_PWR (red): it indicates the power supply (24VDC) coming from the heat pump.

L_RX (blue): it indicates the ingoing communication data packets between the heat pump and the split board.

L_TX (green): it indicates the outgoing communication data packets between the heat pump and the split board.

L_ALL PDC (red): when blinking reveals the presence of an alarm.

L_ALL SPLIT (yellow): when blinking indicates the malfunctioning of one or more probes connected to the split board:

N° Blinks	Probe
3	B2
4	B3
5	B4
6	B5 (4-20)
7	B7
8	B5 impulsive

L_FLUX (blue): it indicates that the flow meter is working:
 - Light on: 4-20 mA flow meter.
 - Blinking light: impulsive flow meter.

L-3-Ways: it indicates the status of the 3 way relay:
 - ON phase on DHW.
 - OFF phase on system.

L_Circ: it indicates the status of the water pump relay:
 - ON: water pump ON.
 - OFF: water pump OFF.

L_Heat: it indicates the status of the relay that manages the "heat" output. It's assigned to the management of the "integration" heating element:
 - ON: "heat" ON.
 - OFF: "heat" OFF.

L_AUX: it indicates the status of the AUX output relay, clean contact NO-C-NC:
 - ON: relay ON.
 - OFF: relay OFF.

L_Y3: indicates the status of the PWM output for the management of the water pump. The intensity of the light is directly proportional to the speed of the water pump.

L_1/0: it indicates the status of the remote OFF (1/0):
 - closed contact (+ 24 V).
 - OFF open contact.

L_E/I: it indicates the status of the winter/summer contact:
 - ON winter (+24 V).
 - OFF open contact (summer)

L_AUX:

it indicates the status of the AUX (Plant Aware):

- ON: contact closed (enabled plant aware) +24 VDC.
- OFF: contact open (disabled plant aware) disabled AUX.

L_COM (green):

diagnostic light that shows the working status of the board.

12.8 TSplit installation

Inside the split unit it's installed the TSplit board.

Its primary function is reading the signal coming from the temperature probes, the flow meter, the remote and digital inputs and outputs. (The details about the connections are indicated at page 111)

For the communication between the heat pump and the TSplit board it's required a cat. 7 shielded ethernet cable with metal connection plugs in order to guarantee the shielding continuity. Separate conduits must be laid so that the communication cable will run in a dedicated line.

This same cable will also provide the 24 V power supply for the board and other devices compatible with a 24V connection (conn 7).

The board is equipped with quick connectors, in order to properly carry out the electrical connections use a screwdriver as shown in the picture below.

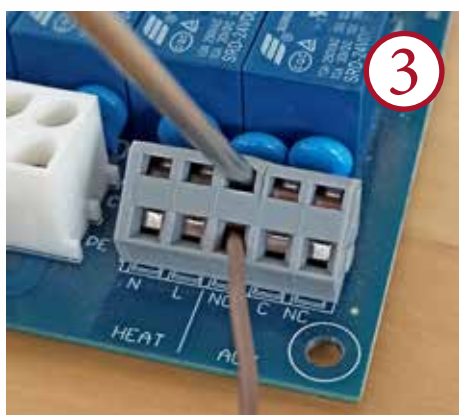
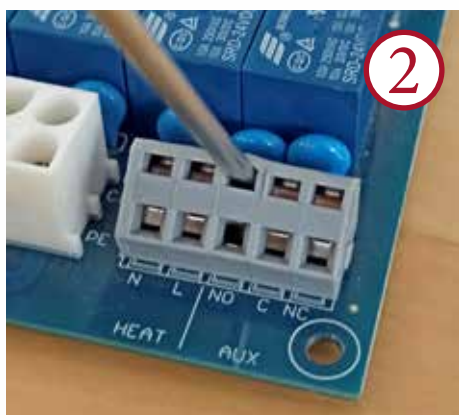
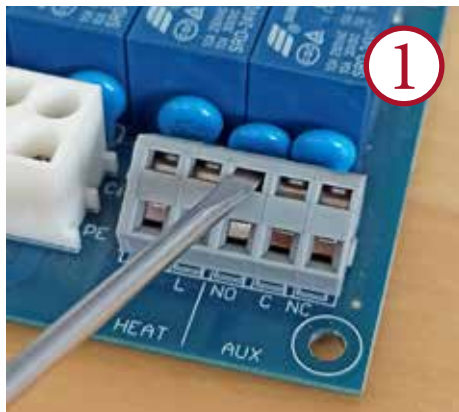

12.9 230 V power supply connection, CONN 1

The TSplit board requires a 230 V power supply connection, use a 3x1.5 sqmm cable and connect it to CONN 1 (PE-GND, L – PHASE 230 VAC, N – NEUTRAL 230 VAC)

This cable must be then connected to the heat pump terminal board and more precisely to the single phase service connection.

The 230 V connection powers the 3 way valve, the water pump inside the split cabinet, and the electromechanical actuator that supplies the auxiliary heating element.

12.10 Description CONN 3 connection and AUX relay configuration

The connection CONN 3 allows the management of two auxiliary relays. The first relay (pole 1 and 2, pic.3 page 45) controls a 230 V phase to manage a contactor for the auxiliary heating.

The second relay (poles 3, 4, 5, pic. 3 page 45) controls the contact NO – C – NC for the auxiliary integration and accessory functions.

Through the Hb14 mask it is possible to configure the two relays as shown below.

I/O Config.	Hb14
Templari Split board	
Digital Output	
Heat Integration Out	
Plant+DHW	
Auxiliary Out	
Integer DHW only	

The relays can be configured with the following functions:

- Relay 1: DHW integration, system integration, DHW + system integration
 - o Default: DHW + system integration
- Relay 2: DHW integration, system integration, DHW + system integration, general alarm, defrost/oil recovery.
 - o Default: DHW integration

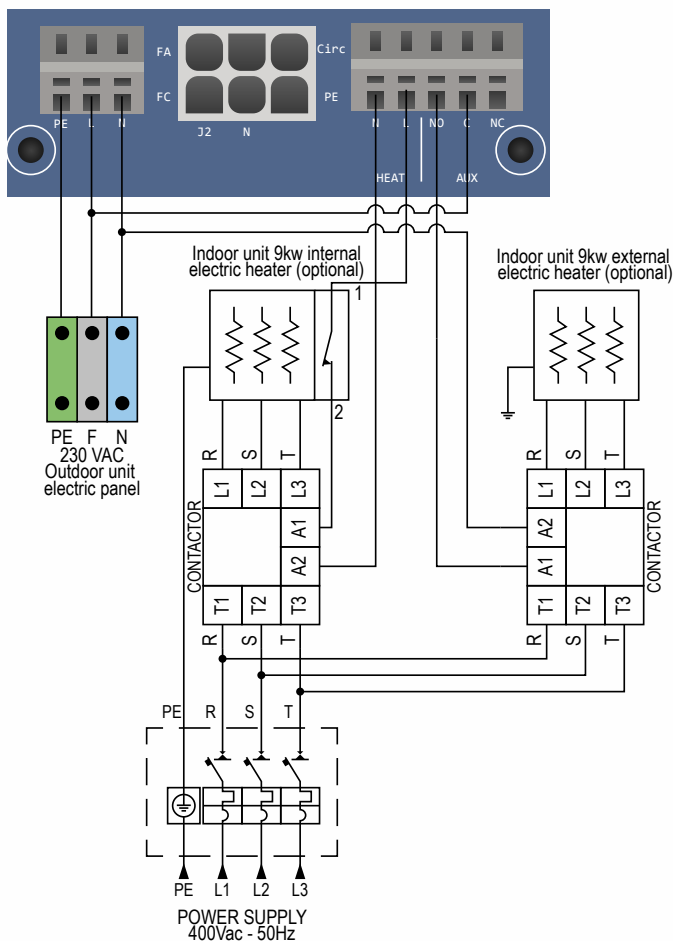

12.11 Connection CONN 5 and digital inputs description

The connector CONN3 allows the management of the B2, B3 probes and the programmable digital inputs. In order to enable the digital inputs listed below, connect a “clean contact” relay, or similar device, between the chosen contact (pin 8-10) and +24VDC (pin 7). Closing the contact the pertinent function will be enabled.

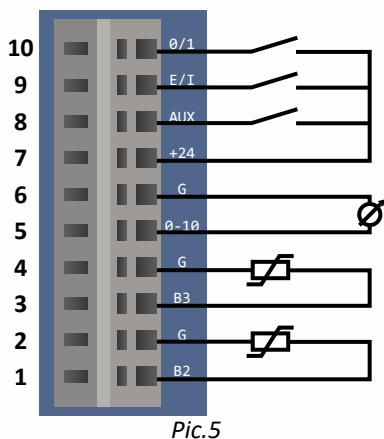

Pic.5

Through the Hb15 mask it is possible to select the function of each digital input.

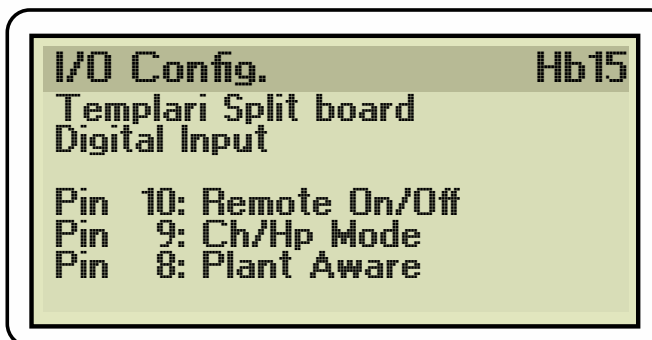

The functions available for each digital input are:

- Plant Aware (DI10 μ PC), winter/summer selection (chiller/heat pump, DI1 μ PC), disable DHW (only DHW, DI5 μ PC), Solar Boost (DI6 μ PC).

The default configuration is the following:

- Pin 8: Plant Aware contact (DI10 μ PC)
- Pin 9: summer/winter switching contact (DI1 μ PC)
- Pin 10: remote ON/OFF contact (DI8 μ PC)

12.12 HCC connection (CONN7)

For the connection of the HCC device it is possible to use:

- Power supply 24 VDC from the contacts GND (5) and +24 VDC (6)
- Bus signal A (+ BMS) and B (- BMS) respectively from the contacts L+ (3) and L- (4).

See pic. 7

Remember to properly connect the shield of the communication cables to the ground connection of the split frame, make sure that the ground connection of the split is properly connected to the ground of the electrical system.

12.13 TSplit board description and antifreeze

The Tsplit board is activated from the mask Hb13 by setting it to ON.

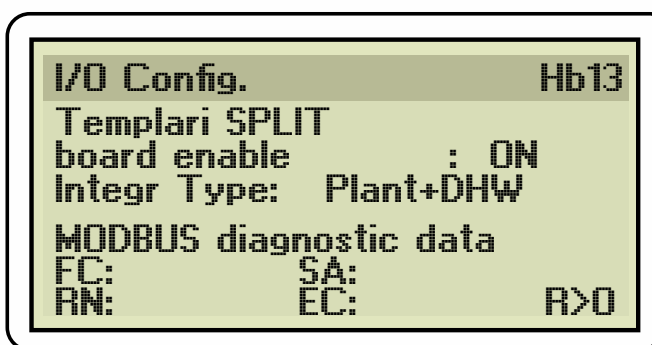

Once activated, the board will automatically start the communication with the heat pump with no further action required.

If the TSplit board for any reason fails to communicate with the heat pump the antifreeze function might be turned on.

This function probes the temperature of the water every 15 minutes for 90 seconds, in order to understand if the circulator must be kept on to prevent a possible freezing of the water inside the pipes.

The antifreeze function checks the water flow and when present reads the temperature of the probes B4 and B7. If the temperature read is below 5°C the water pump will be kept on until reaching 7°.

If the water flow check up fails, the antifreeze function will be

aborted after 90 seconds even if the temperature is below 5°C.

⚠ ATTENTION!

When the system is filled up with water, do not close the inlet and outlet taps. As it may lead to the freezing of the system.

TS connect board

Board assembled inside the heat pump that conveys the BMS communication bus, Fieldbus communication bus and +/-24V supplying inside the cat. 7 ethernet cable.

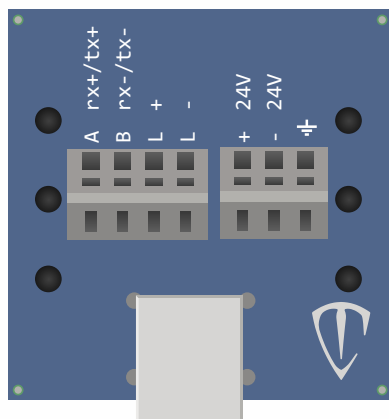

uPC control board - TS connect board connection diagram

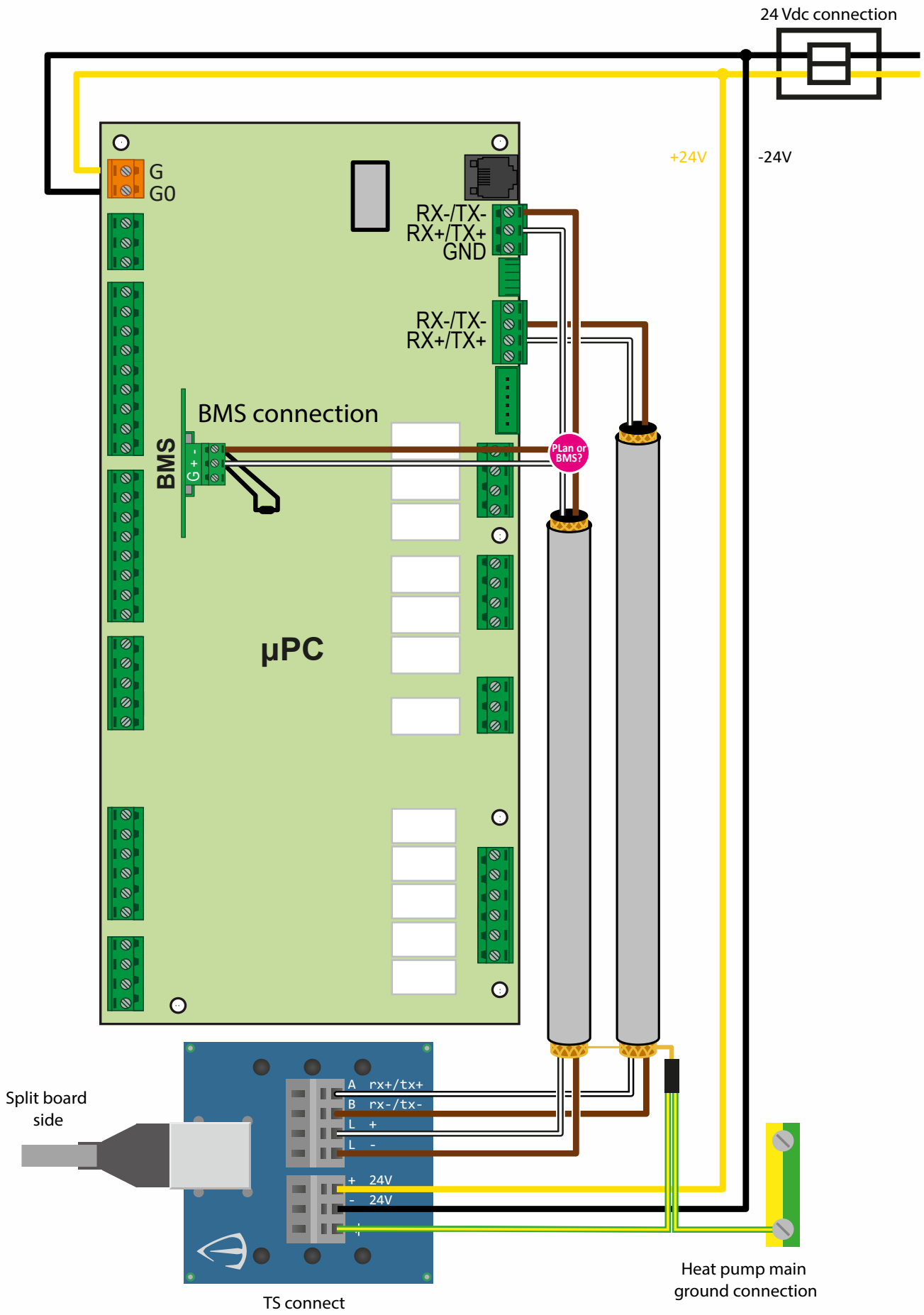

12.14 Plant Aware Function

Available from software version 13.69.001 of 07/10/2020

The Plant Aware function (PA) modifies the hysteresis for the start of the machine in comparison to the heat pump setpoint according to the input (opening\closing) of the contact ID10. This function is only available for heat pumps equipped with flow meter; it works through the digital input ID10 used for the flow switch in the models equipped from the factory with the flow switch.

If the contact is closed, the heat pump works to reach the setpoint according to the standard hysteresis

If the contact is open, the heat pump goes to "sleep" mode and the hysteresis automatically modified in order to start 10 degrees below the setpoint. The main purpose of this function is avoiding unnecessary heating\cooling of the puffer tank.

PGD1

The function can be enabled and disabled with the PGD1 panel from the mask Gfc65.

K-Touch

In this case there aren't any ROOM sensors or cMix boards.

The K-Touch Plant Aware system function overwrites and replaces the PA settings of the heat pump.

And therefore, if the panel enables the PA function, it won't be possible to disable it from the PGD1.

The ID10 is the contact used to manage the PA function.

HCC

The PA function can be enabled using the HCC panel from the mask "More".

In this case there is at least one ROOM sensor or a cMix board.

The HCC PA system function overwrites and replaces the PA settings of the heat pump.

If neither a ROOM sensor nor a cMix board are triggered and therefore there are no active contacts, the HCC system enables the "SLEEP" mode, otherwise the heat pump will continue working as usual.

N.B. The ID10 contact will be disabled

Settings for service staff only

The ID10 contact closes when you get demand from at least one device or section of the circuit. (Logic OR of the water pumps activation).

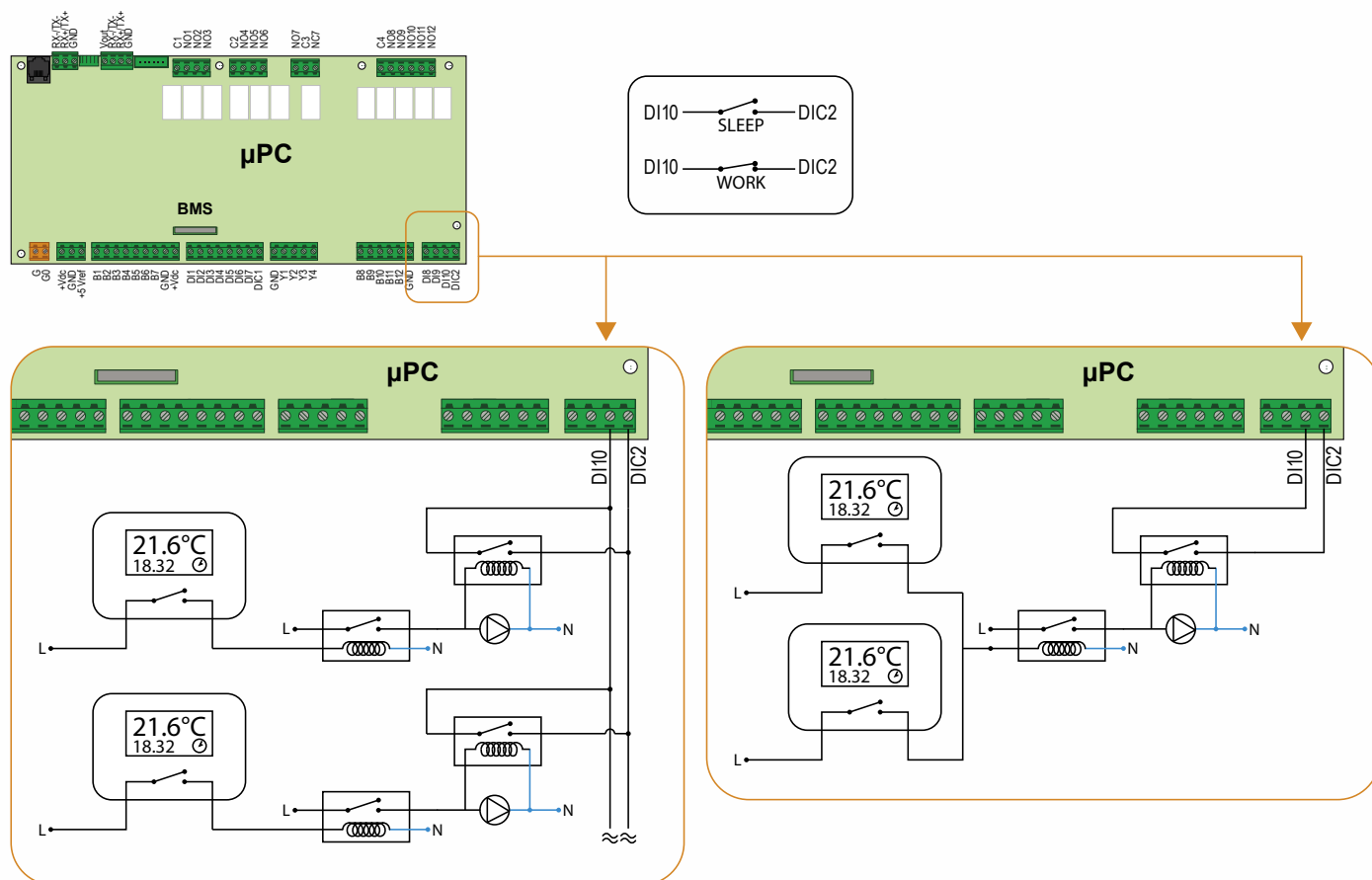

12.15 Wiring pLAN net - “multi-KITA”

If more unit **KITA Templari®** are connected each other it is possible to make them interact by a pLAN “multi-KITA” logic; it is possible to connect 4 units in cascade at last.

It is necessary to connect the machines through a bipolar cable shielded according to the scheme below:

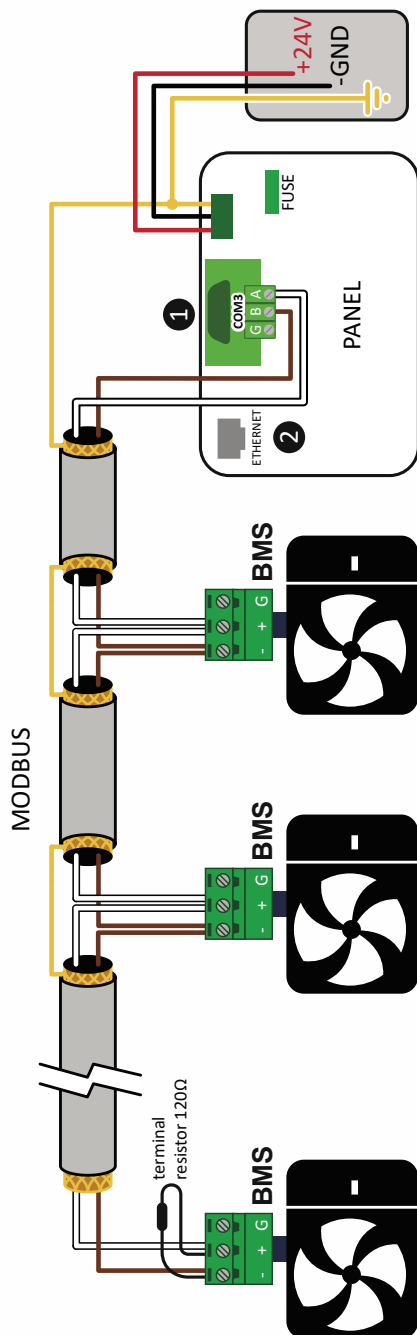

- 1 Communication port with the heat pump or to other devices. It always corresponds to the COM3 Port.
- 2 Ethernet cable for switch or router connection.

The wiring has to be made in the dedicated port on the board “P-LAN 2” (point 11 of the scheme in chapter 13.10).

13 Electronic board

KITA S - S 3phase - S plus - S plus 3phase
 - Si - Si 3Phase - Si Cold - Si Cold 3Phase
 - Si Plus - Si Plus 3Phase - Si Plus Cold - Si
 Plus Cold 3Phase - Mi - Mi 3Phase - Mi
 Cold - Mi Cold 3Phase - Mi Plus - Mi Plus
 3Phase - Mi Plus Cold - Mi Plus Cold
 3Phase - L33 - L42 - L66 - L66 Cold - Li Plus

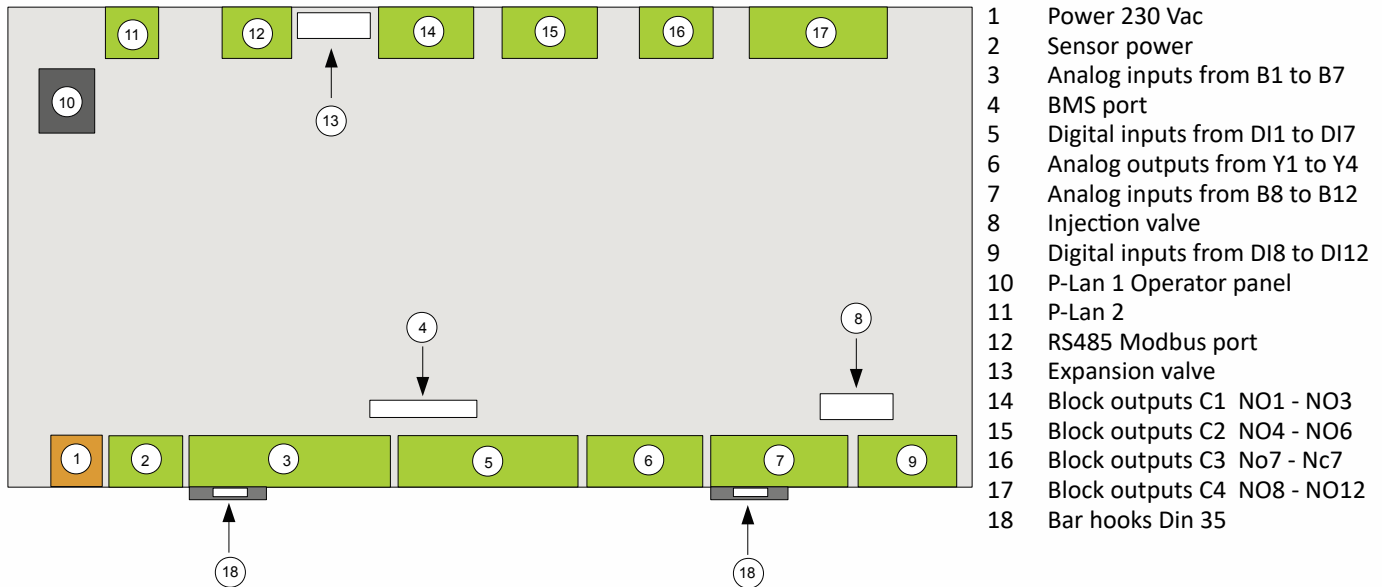

- 1 Power 230 Vac
- 2 Sensor power
- 3 Analog inputs from B1 to B7
- 4 BMS port
- 5 Digital inputs from DI1 to DI7
- 6 Analog outputs from Y1 to Y4
- 7 Analog inputs from B8 to B12
- 8 Injection valve
- 9 Digital inputs from DI8 to DI12
- 10 P-Lan 1 Operator panel
- 11 P-Lan 2
- 12 RS485 Modbus port
- 13 Expansion valve
- 14 Block outputs C1 NO1 - NO3
- 15 Block outputs C2 NO4 - NO6
- 16 Block outputs C3 No7 - Nc7
- 17 Block outputs C4 NO8 - NO12
- 18 Bar hooks Din 35

13.1 Digital outputs

NO1	Integration
NO2	Defrost
NO3	Air-air or air-water indicator
NO4	Circulation pump
NO5	Condensate drain heating
NO6	Plant integration demand
NO7	General alarm
NO8	DHW integration demand
NO9	3-way valve
NO10	4-way valve
NO11	Oil heating
NO12	Desuperheater

13.2 Digital inputs

DI1	Summer-winter switch
DI2	Thermal sensor
DI3	High pressure switch
DI4	/
DI5	Disable plant
DI6	/
DI7	System auxiliary heater security
DI8	Remote on-off
DI9	Switch modbus controller
DI10	Flow switch

13.3 Analog outputs

Y1	/
Y2	Internal fan KITA Air
Y3	PWM circulator
Y4	External fan KITA Air

13.4 Analog inputs

B1	Subcooling
B2	Radiant probe
B3	Domestic probe
B4	Return probe
B5	Flow meter
B6	Head compressor probe
B7	Flow probe
B8	External temperature probe
B9	Drain probe
B10	Suction probe
B11	High pressure transducer
B12	Low pressure transducer

13.5 Wiring diagram KITA S / S Plus mono-phase

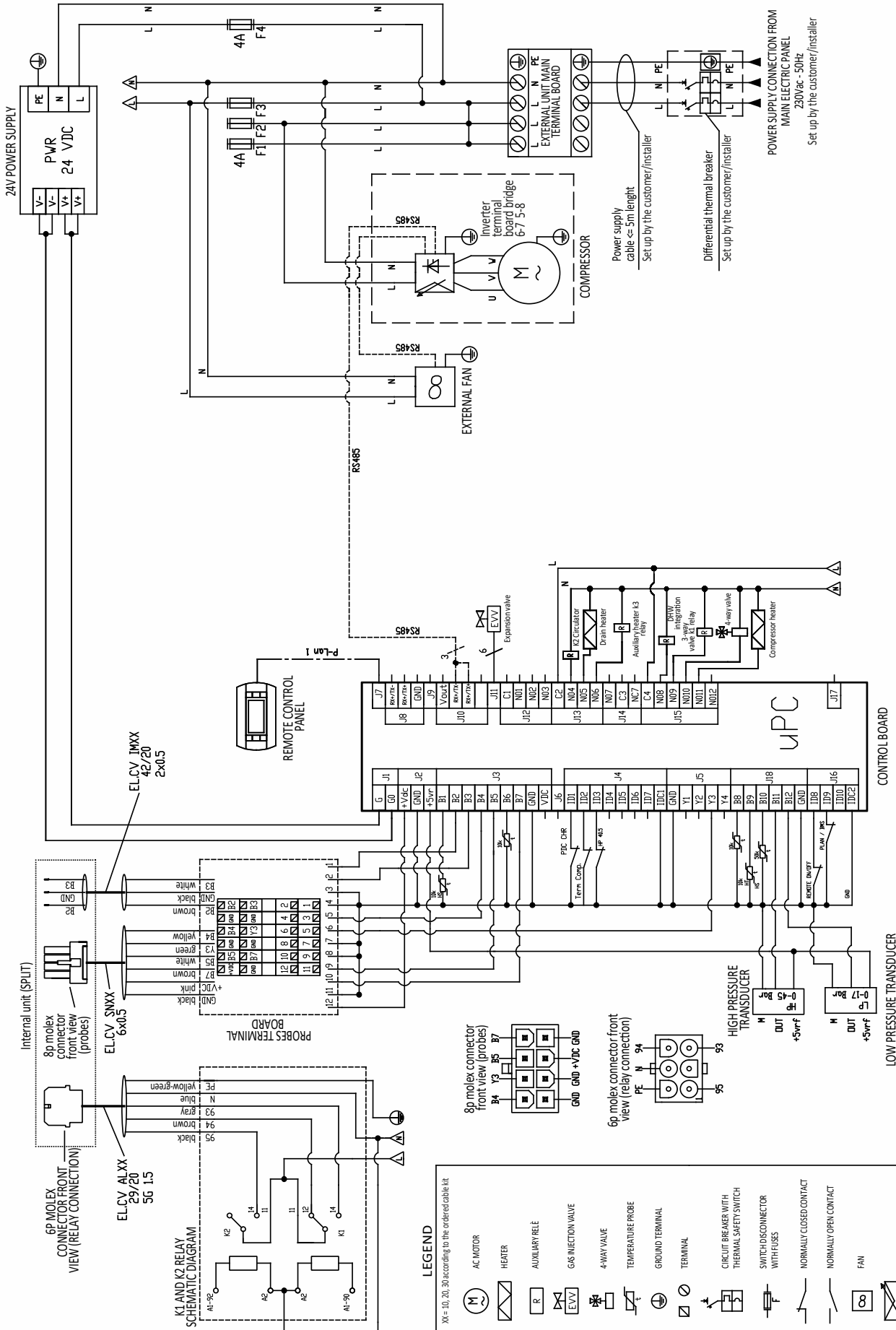

13.6 Wiring diagram KITA S 3Ph / S 3Ph Plus

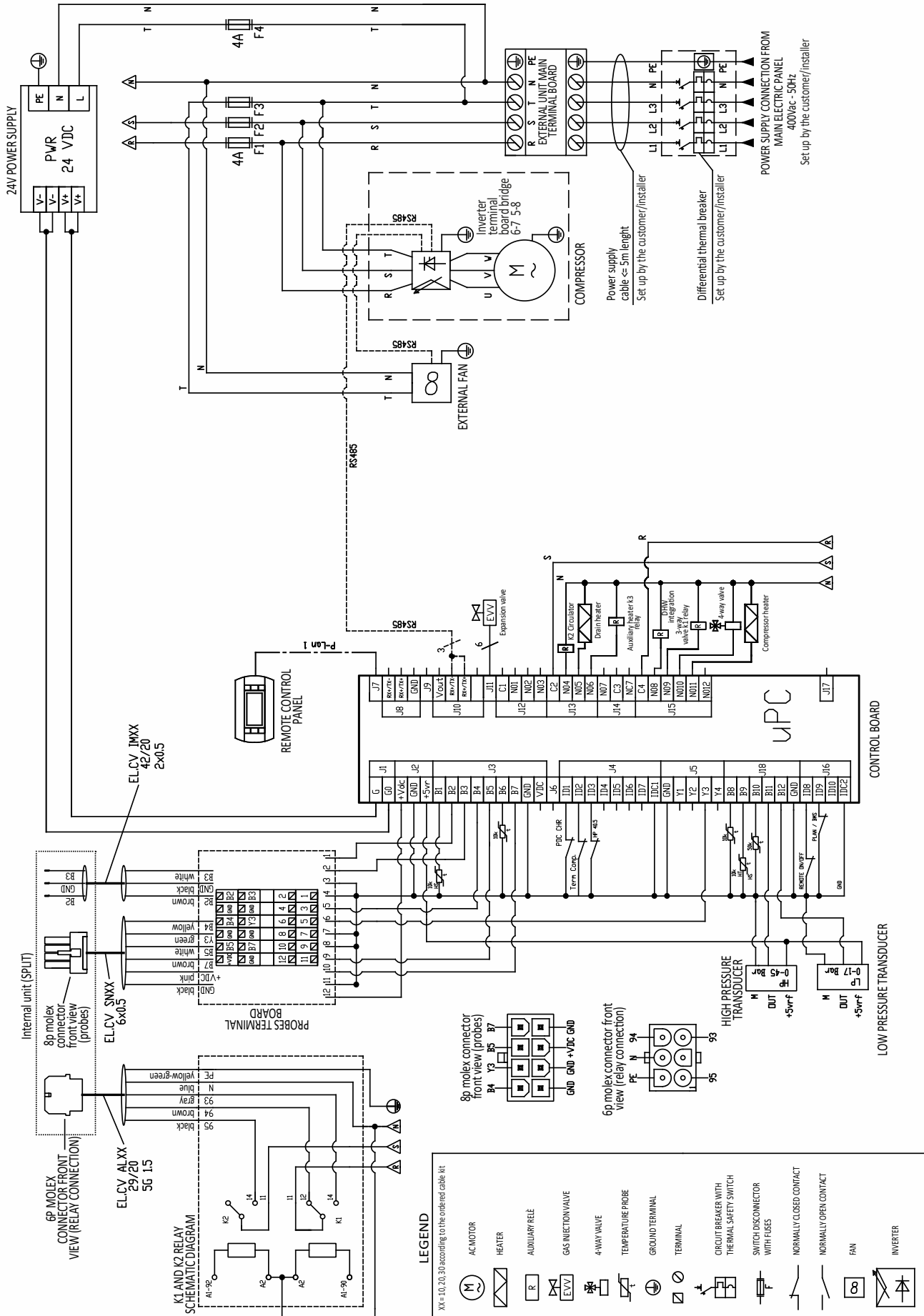

13.7 Wiring diagram KITA Si / Si Cold / Si Plus / Si Plus Cold / Mi / Mi Cold / Mi Plus / Mi Plus Cold mono-phase

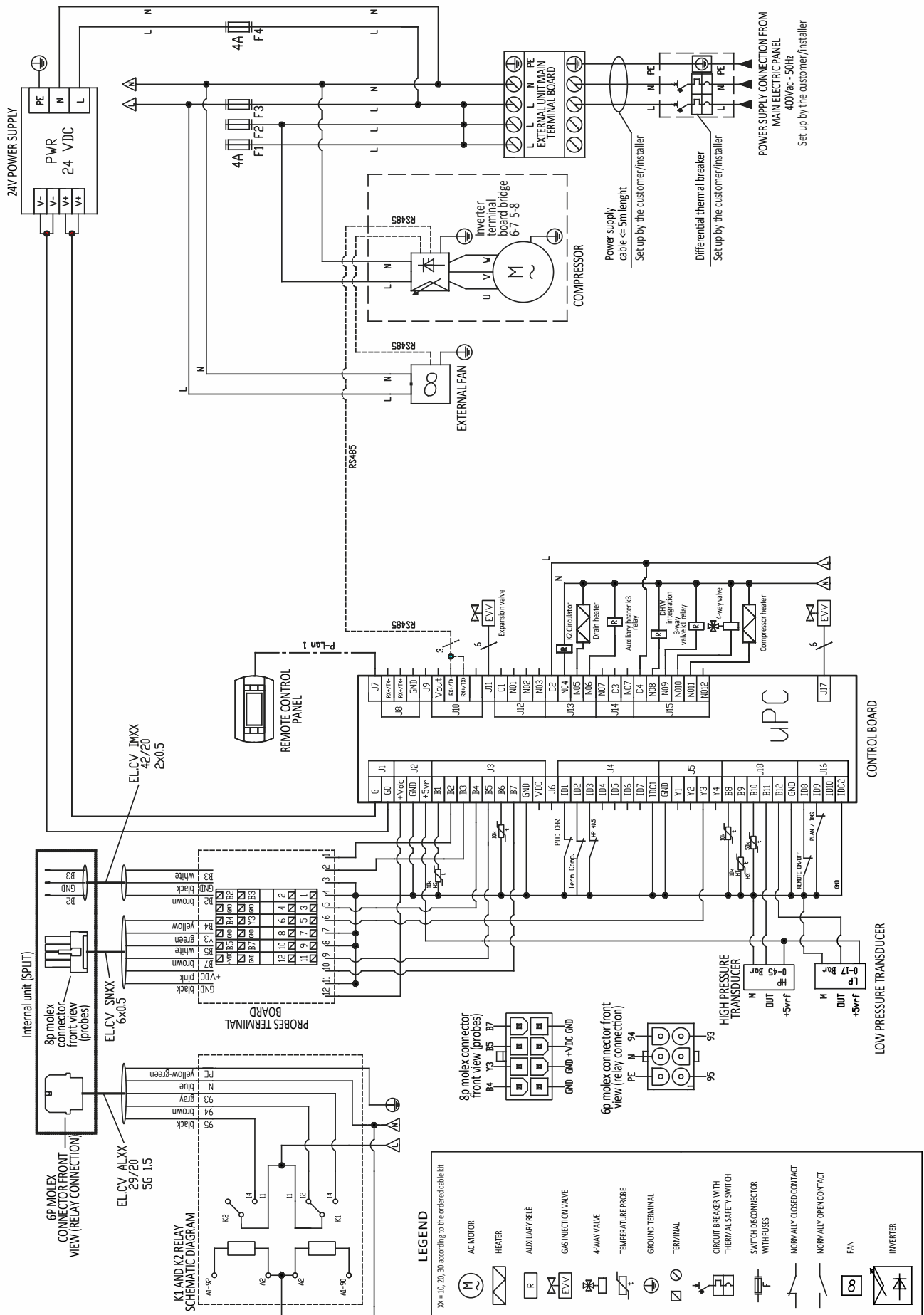

13.8 Wiring diagram KITA Si 3Ph / Si Cold 3Ph / Si Plus 3Ph / Si Plus Cold 3Ph /Mi 3Ph / Mi Cold 3Ph / Mi Plus 3Ph / Mi Plus Cold 3Ph / L33 / L42

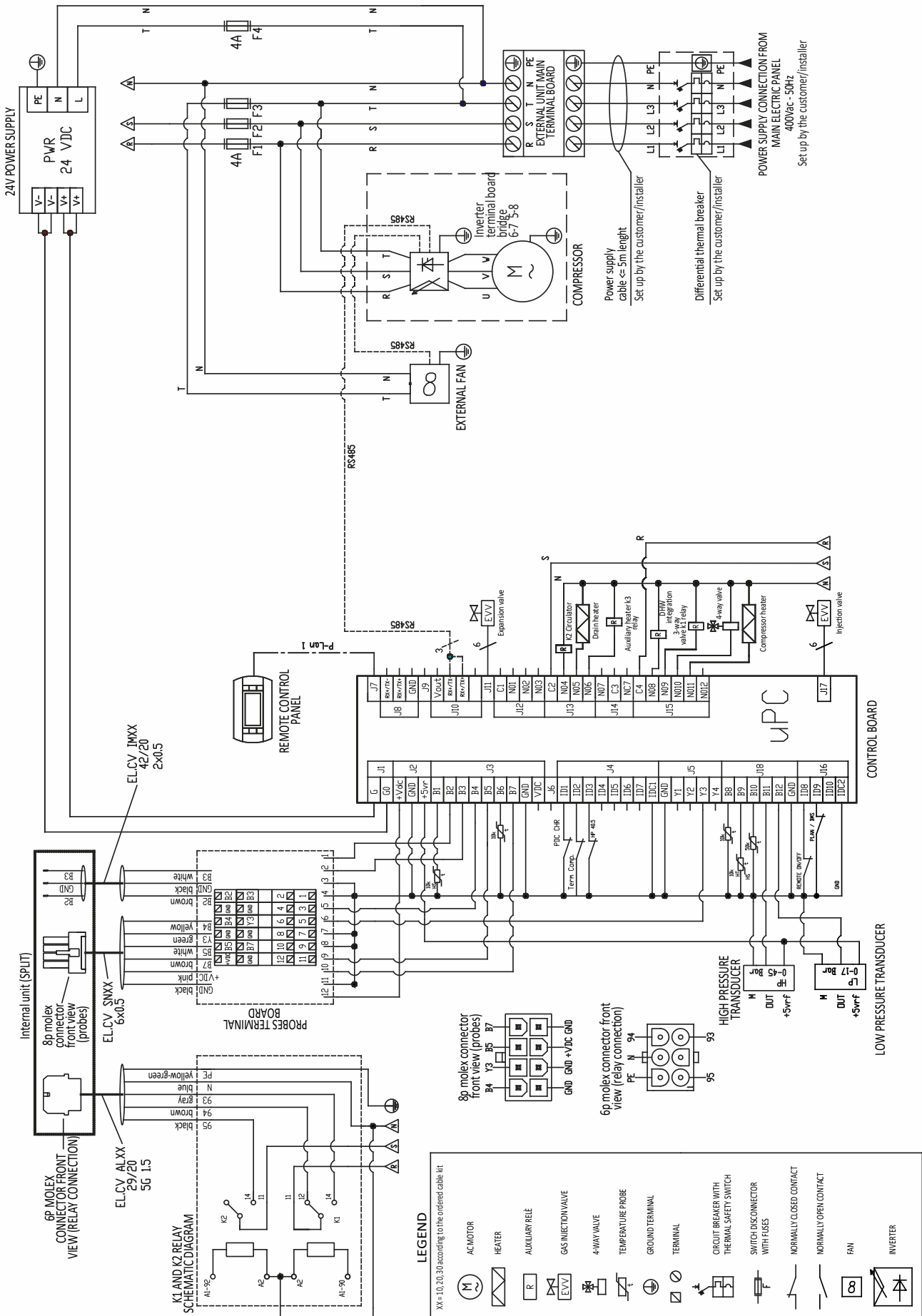

13.10 Internal wiring connection diagram

13.10.1 Circulation pump

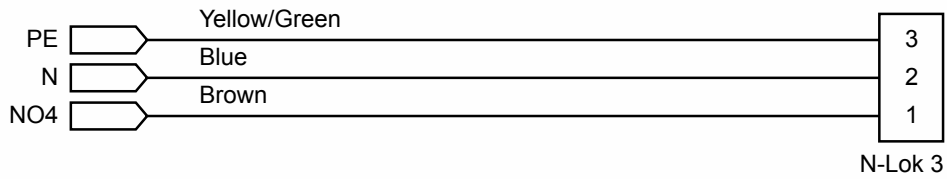

13.10.2 Fan

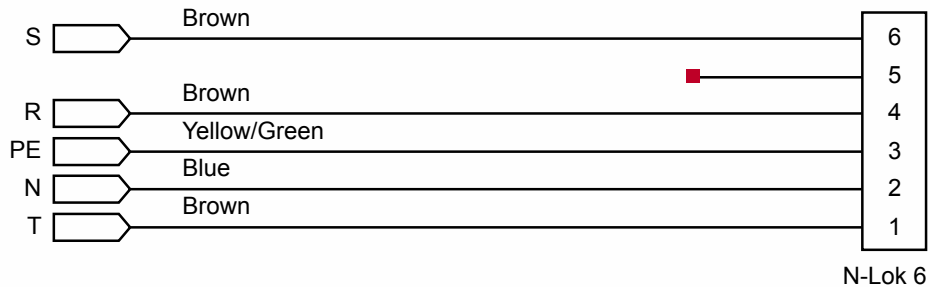

13.10.3 4-way valve and carter resistance wiring

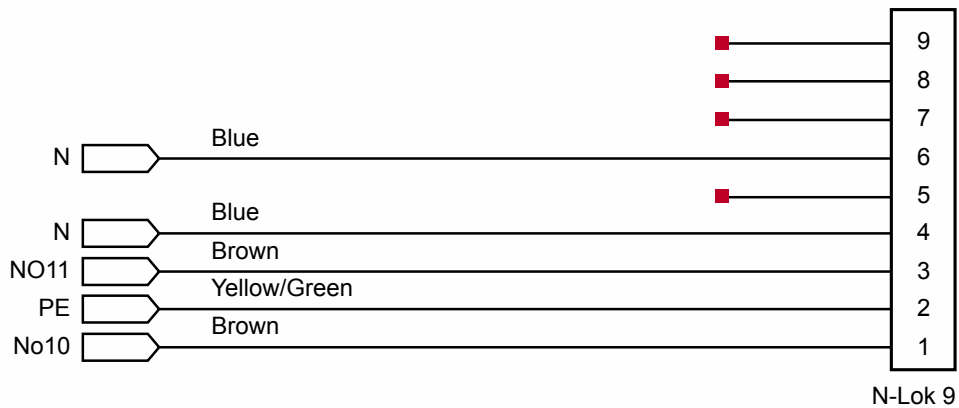

13.10.4 wiring probe

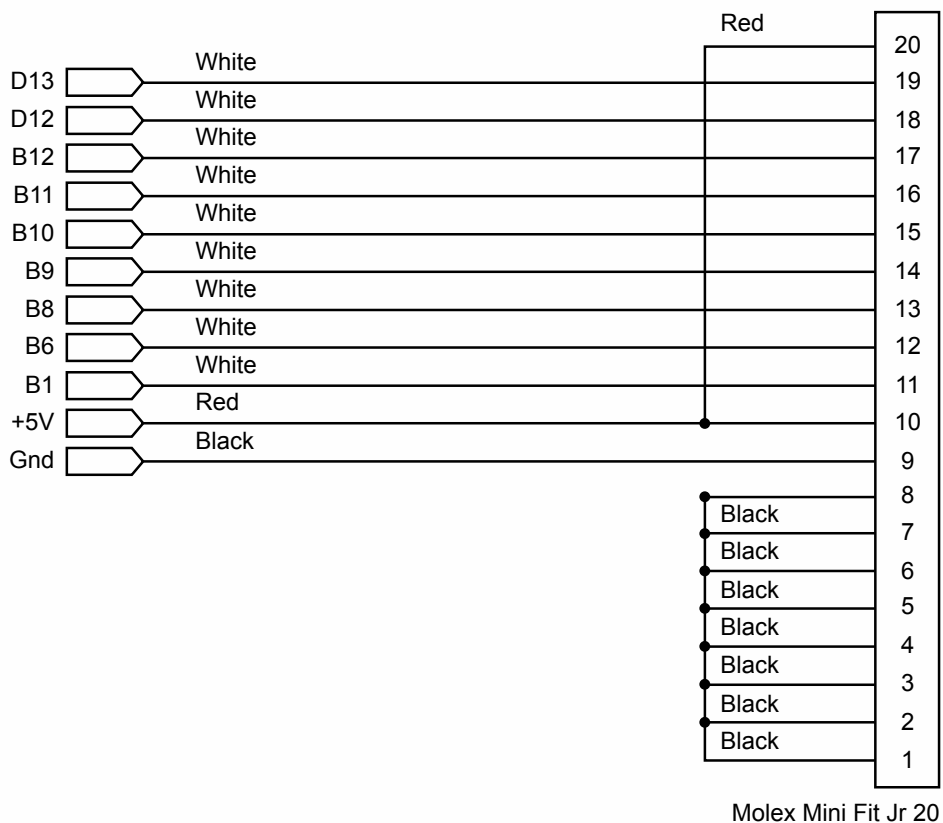

14 Start up

the system start up has to be made by a competent staff with a specific formation. The connection of the cooling circuit has to be made by refrigeration engineer qualified and equipped with the special license.

Following the correct hydraulic and electric installation of the heat pump (HP), as specified in the previous pages, proceed as follows.

14.1 Preliminary checks

Make sure that power cable of HP have a suitable section as recommended in this manual, on the base of the power used and the length of the cables themselves. The suitable electrical device protections have to be inserted.

In the same way verify the signal cables of outside unit (sensors) and of inside unit (sensors, flow switch, circulator, 3-way valve) and make sure they have the features demanded.

Control the Y filter is correctly connected in the return tube of HP so to avoid blocks or malfunction plate heat exchanger. Make reference to this manual to use the right kind of tubes (diameter/thickness) of the cooling circuit between the inside and outside unit.

After having controlled the points mentioned above you can proceed with the start up .

i NOTE!

Be careful after the start up of the HP, the automatic function of oil heating will be activated (the duration depends on the time necessary to bring to temperature the oil contained in the compressor, so according the starting temperature).

i NOTE!

If the inside and outside units are placed at different heights, with more than 3 meters difference, it is necessary to insert some siphones to recover the every three meters in the cooling line named "GAS".

14.2 Test and start up

- Enter to menu "Assistance": PRG --> G. Assistance --> g. Manual management --> ASSISTANCE PASSWORD

Flow check:

- Screen Gg01 N04: Pump primary, set manual function "MAN".
Verify the correct water circulation of the circuit. After 5 start up attempts if the circulator doesn't have the right flow, an alarm red led will be lited up on the command panel, and it is necessary to check the effective opening of the hydraulic circuit (portcullis), air in the system or block in Y filter can cause problems. Provide to remove it.
- Screen Gg01 N04: Pump primay, set authomatic function "AUT"



Vent valves , split version.

Compressor running:

Every HP is tested by the manufacturer before the supplying, in any case we suggest to make short running, to not solicit the new compressor too much. In this concern we suggest to use the rps compressor manually at a medium value (50-60 rps) for one/two hours at least.

- Enter to menu "Assistance": PRG --> G. Assistance --> g. Manual management --> ASSISTANCE PASSWORD
- ScREEN Gg05 set CH/HP manually "MAN" and set the grps (60). At that point turn on the heat pump (Mode ON) and wait some minutes till the icon of compressor appears at the left bottom.

! WARNINGS!

During manual operation, probe B3 is ignored. If the functions setted in manual (MAN) during the running are not set back in automatic (AUTO) at the end, the heat pump will continue to work until it causes a high pressure alarm.

Verify the correct operation:

- Enter to the menu "D. inputs/outputs" to check the different temperatures from sensors
- Screen D01: B1 it shows the liquid undercooling value in the heat pump, it has to be included between 3 and 4, about 35°C of water reached (see B7). If the HP is started up during the hot season, set the speed of the fan to control the undercooling (Menù G. Assistance --> g. Manual management --> G. Assistance --> g. Manual management --> ASSISTANCE PASSWORD --> Screen Gg02: set "Fan speed" manually MAN e "Demanded power" a 5%. After checking the value of the B1 probe, reset the values as they were previously.
- Screen D02 and D04: check the temperature of the probe B7 (water flow) and compare it to the probe temperature B4 to see if the circulator works with a right deltaT (less than 8).
- Screen D06 and D04: check the B11 (condensation) with B7 (water flow): the difference between the two sensors has to be included between 1 and 2 degree for a correct operation. If the deltaT is more verify there aren't possible bottlenecks in the hydraulic and cooling circuit.

- Screen D08: verify the SH value (overheating) is included between 4 and 5
- Screen D15: verify, established the conditions (B7 at 35°C, compressor 60 rps and water $\Delta T < 8$ and SH between 4 and 5, undercooling between 3 and 4) the overheating drain has to be about 20. During the normal operation, free compressor, this value can reach 45K.
- Screen D16 (only in versions Kita-L, L42 e L66): check the correct operation of the injection valve, considering over 12°C outside the valve is off.
- Menu G. Assistance --> g. Manual management --> ASSISTANCE PASSWORD --> Screen Gg06: activate a defrosting cycle, setting "Start defrosting cycle" in SI (when the cycle is finished the function comes automatically back to AUT).
- Menu G. Assistance --> g. Manual management --> ASSISTANCE PASSWORD --> Screen Gg01: "N09 Valv.3V ACS", set manual MAN, if the 3-way valve is installed to the management of domestic hot water, to test the right operation .
- Take back all settings from manual MAN to automatic AUT.
- During the domestic production verify the DHW has the priority on heating/cooling, the difference of temperature between the probes B7(water flow) and B3(domestic probe that has to be placed on the top of the tank) can't be more than 3 degrees.
- Verify the work tensions and the network frequencies are in these ranges:
230/1/50 -> values $\pm 6\%$
400/3/50 -> values $\pm 6\%$

positive air temperatures; by the way it requires more refrigerant than project data. The heat pump Kita has to be dimensioned to work at the maximum just at minimum outdoor temperatures. the electronic valves are optimized to operate in a medium range di funzionamento and the reason why oversized valves aren't installed is that they would work too close causing instability of the system. Possible solutions:

- control the correct operation of the valve
- control that in the HP Kita there is the right quantity of gas
- replace the heat pump is wrongly oversized compared to the thermal need of the building.

NOTE!

Some possible malfunctions can be intercepted in the start up. To extend the heat pump life is useful to check the value of the probe B11 (condensation) and subtract this value from B7 (water output). The delta T risultant, in case of correct operation, it has to be between 1,5 and 2, according to the thermal load of the heat pump and the water flow system side. Contrary if the delta T is more than 5 allora, it might have occurred one of the following problems:

- air in the fridge circuit;
- air in the hydraulic circuit;
- low flow water side;
- defective electronic valve (it works too close wrongly increasing condensation value).

An high delta T could cause high pressure alarms, in particular during the production of high temperature water.

NOTE!

Other problem easily detectable is the steady opening 100% of the electronic valve.

Possible causes and solutions:

- refrigerant gas missing in the cooling system; this make the electronic valve stay open over normal values to compensate de lack of gas.
- heat pump wrongly used. Example: installation of an undersized heat pump compared to the building and it need higher power at target level. In this case for example the compressor works at 100% even with

15 K-Touch Panel

To consult when the K-Touch panel is present.



15.1 Warnings

To be able to monitor the panel remotely using a VNC program, it is necessary that the house is equipped with internet access, and that the HCC Touch panel is physically connected via a network cable to the home router or switch.

The panel comes with the "Easy Access" function already activated, which lasts for the life of the panel. This function allows, using a specific client, to remotely access the panel using a PC or a Smartphone without further configuration, only by entering the user and password of the Easy Access account. Access credentials are provided by email to the customer at the time of activation. For this reason at the time of purchase it is necessary to provide a valid email address where you will receive all useful information.

i NOTE!

15.2 Notes on the plant preparation for K-Touch panel

The K-Touch panel may only be supplied with power via the internal power supply of the machine, otherwise the guarantee expires.



MODBUS cable:	Templari HCC cable (similar Belden 3105A 2x22AWG shielded)
Power cable:	2x1 mmq
Power supply:	HCC POW 24Vdc, 2.5A

Prepare the electrical system for the passage of cable ducts by at least 16 mm in diameter for the passage of only MODBUS cable and power supply for sensors and devices.

Modbus connection

! WARNING!

We recommend using the HCC CABLE data cable

The connections between the BMS board mounted on the machine and the K-Touch Panel must comply with the connections shown in Tab1 and Figure 1.

The K-Touch Panel can also be connected to the PAn network of the μ PC as shown in Figure 6.

Connect the G (Ground) pole of the HCC Connect cable of the K-Touch Panel to the shield of the Modbus data network.
Connect the ground terminal of the power supply to the shield of the Modbus data network.

The shields of the various cable sections, between the various devices that may be present, must be connected in series and NOT inserted in the G pole of each device, as in Figure2

BMS	Data cable	K-Touch Panel	HCC FLOOR e ROOM sensors
GND	shielding socket	shielding socket	
+	A	A	A
-	B	B	B

Tab1

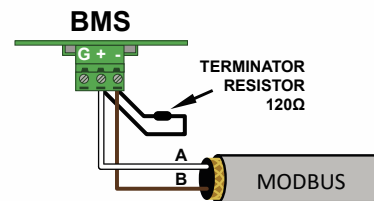

Figure 1

Installation Note:

In case there are more devices, MODBUS data cabling should *not* ever be done with direct branches that form Y or stars.

The connection between a device and the next must take place via "concatenated" connections, connecting in sequence the sensors and MODBUS devices. It is therefore convenient to prepare the fitting of cables for the passage of 2 MODBUS data cables; the first intended for the device in question and the second will be the return to connect the next device.

Each cable duct which ends on a sensor will then have at its inner 3 wirings:

2 MODBUS cables (one that comes inside plus one going out), plus one power supply consists of 2 wires 2x1

An exception is the 2-terminal devices (usually, the heat pump and the HCC panel) which instead will have a single MODBUS cable and one power supply.

- For Data cable less than 10 meters long, use only one 120 Ohm termination resistor, the one onboard the BMS or the one on the last chain peripheral.
- To use the HCC system remotely, via a VNC program, you must connect the RJ45 (LAN1) port on the back of the K-Touch Panel to a Router or Switch via an Ethernet cable.

! WARNING!

The MODBUS network **must always terminate at the ends with a 120 Ω resistor, between terminals A and B.** Usually the network terminations are on the one hand the HCC panel and on the other the heat pump.

⚠ WARNING!

If the plant is designed to directly connected the heat pump to a floor system, such as underfloor heating, without intermediate systems, the absence of condensation is not guaranteed.

16 HCC connection

15.3 Connecting to the Kita heat pump

If you want to use the PGD1 remote control panel at the same time as the K-Touch Panel, you must use a **BMS** card, purchased separately.

If the BMS card is present, a 120Ω resistore must be installed at the both ends of MODBUS network. To enable the HCC to function properly, set the communication protocol to MODBUS RTU 485 via the PGD1 panel (mask Ge01).

Referring to the μPC, make sure you **DO NOT** have the terminal ID09 connected to GND as shown in Figure 5.

With this configuration you can simultaneously use the PGD1 control panel and the K-Touch Panel.

If the K-touch panel is the only display present and it is connected to the heat pump via the P-LAN port then it is necessary that the ID9 contact of the μPC board is connected to the Ground, as in figure 2.

15.4 System overview

This is an example of how to set up the plant.

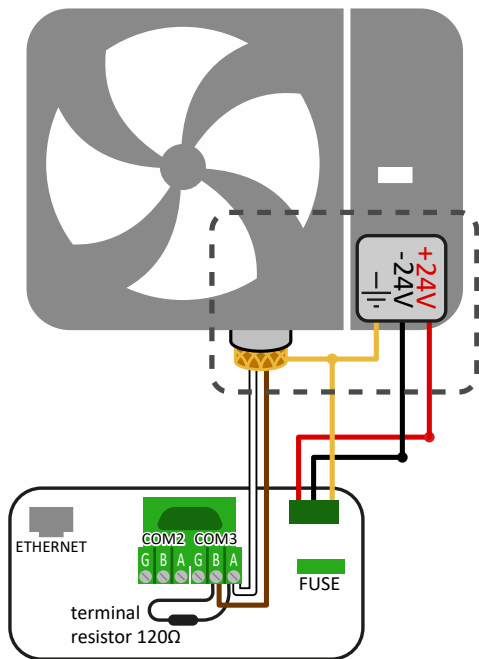
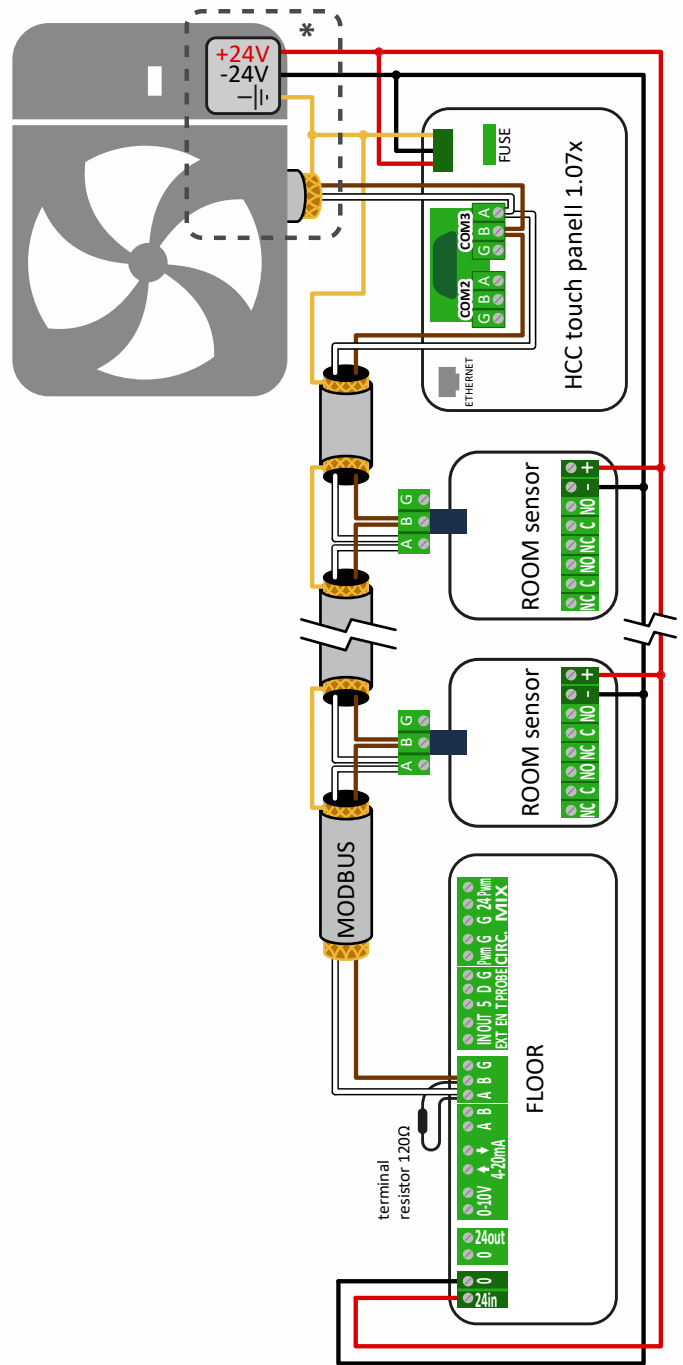
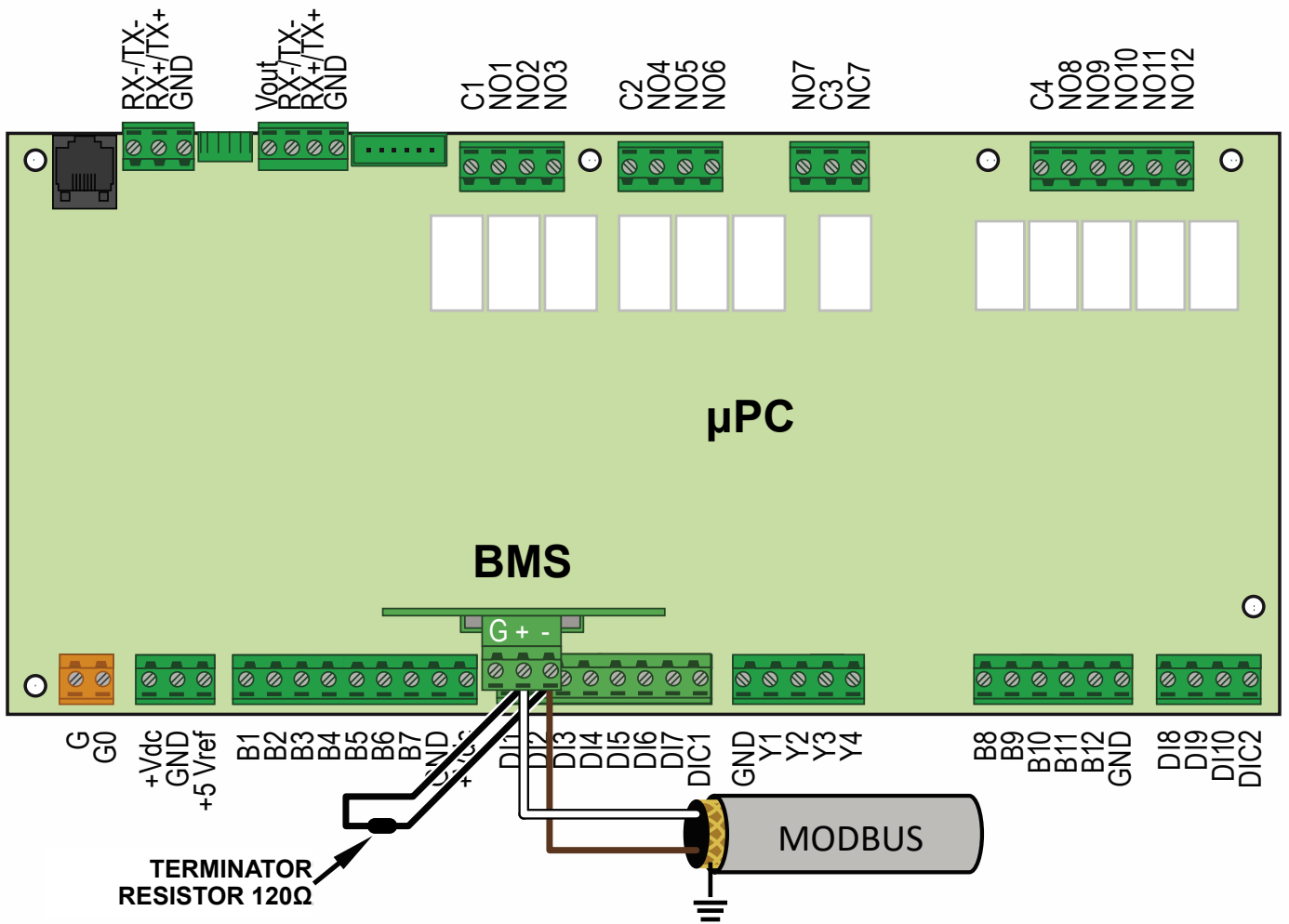

Figure 2



K-Touch panel connected via BMS



K-Touch Panel connected via P-LAN as the only display

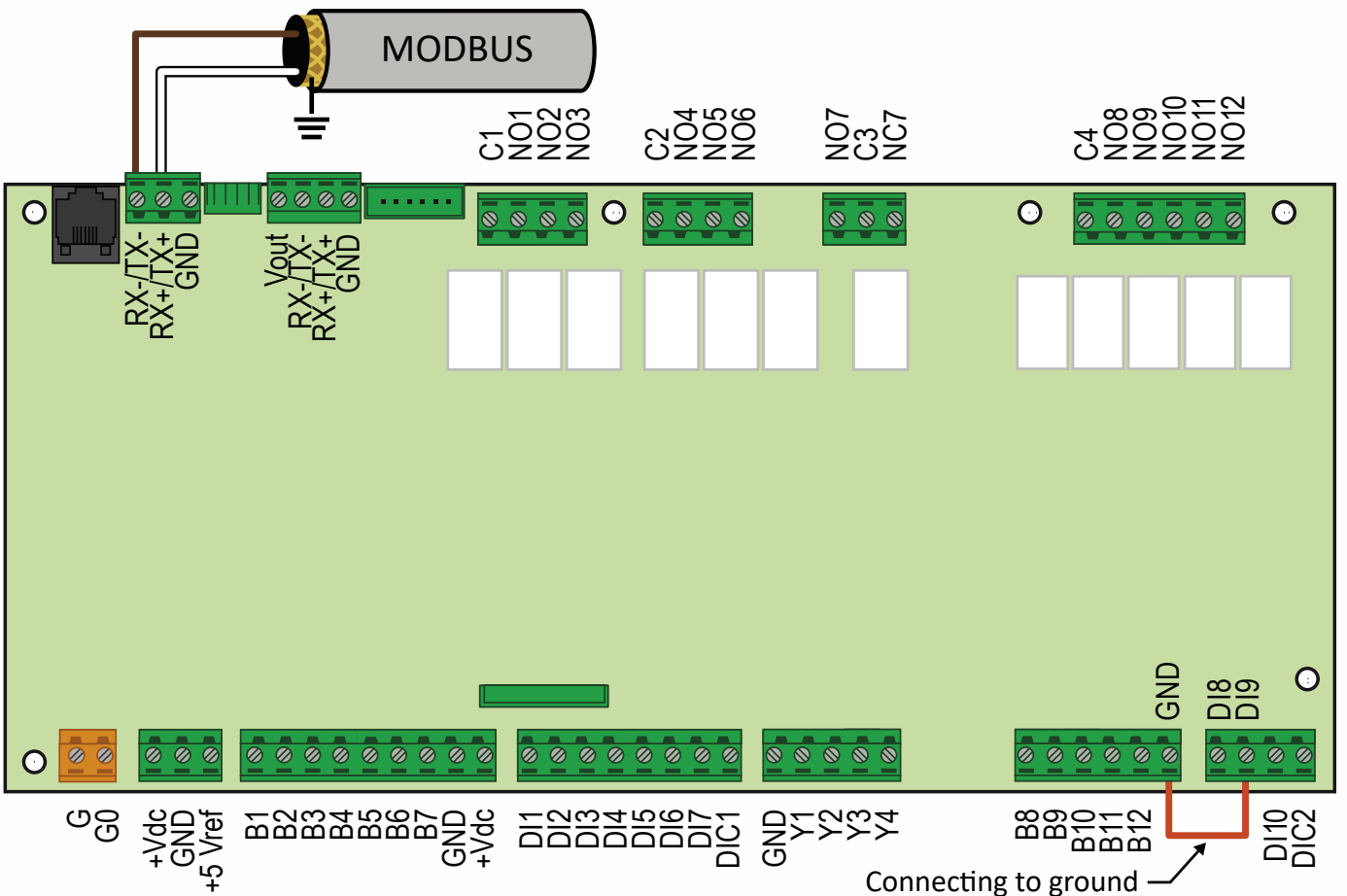

16.1 Exploded view: PPlan connection (7a) or BMS connection (7b)

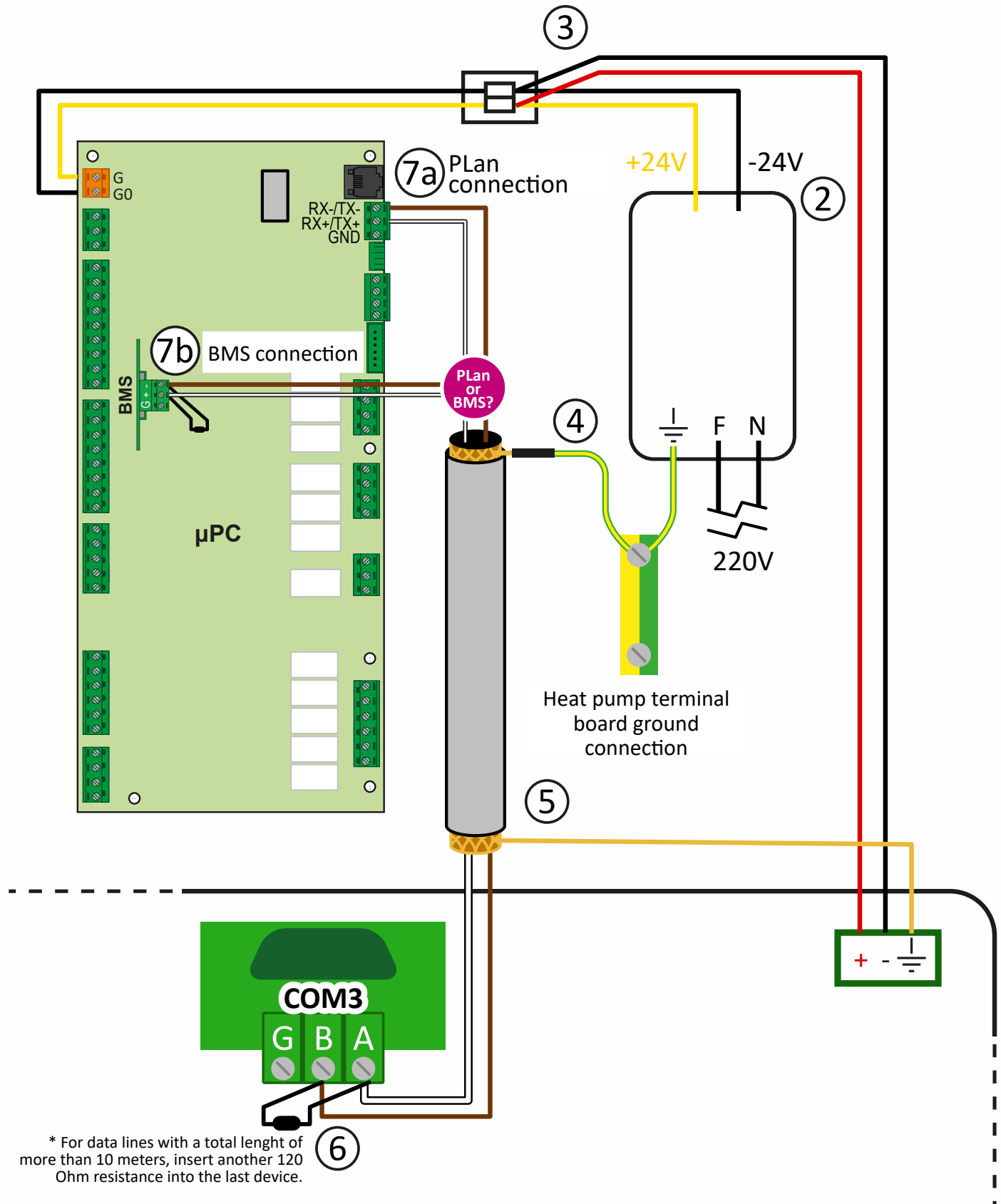

* For data lines with a total length of more than 10 meters, insert another 120 Ohm resistance into the last device.

- ① Panoramic
- ② Power supply
- ③ Compact lever connector
- ④ Green/yellow shield ground connection
- ⑤ Shield
- ⑥ HCC touch panel connection
- ⑦a μPC PPlan connection
- ⑦b μPC BMS connection



① Panoramic



② Power supply



③ compact lever connector



④ Green/yellow shield ground connection

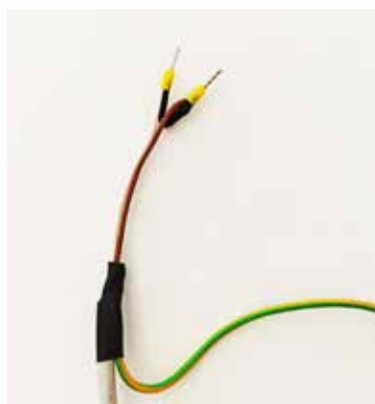

⑤ Shield



⑥ HCC touch panel connection



⑦a µPC PLan connection

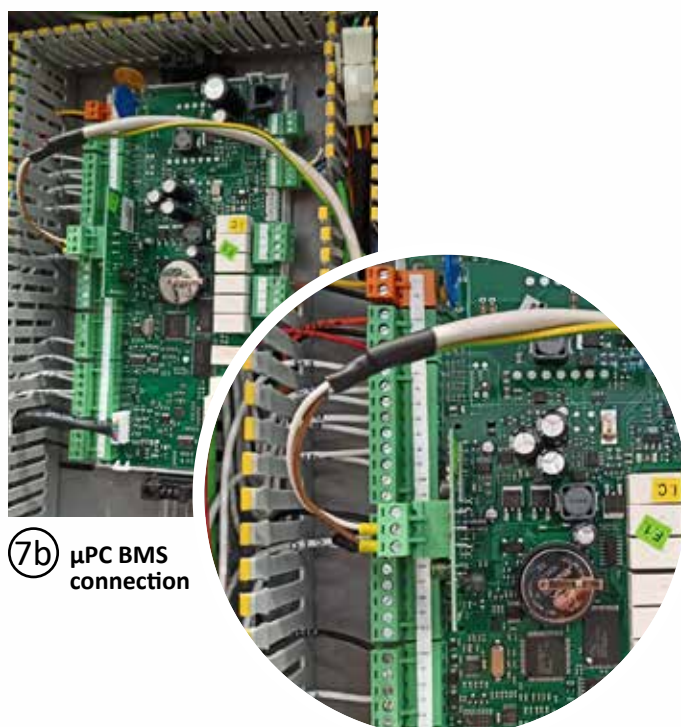

⑦b µPC BMS connection



Watch the video for the K-Touch connection to the heat pump.

17 Control terminal

In Kita Split the terminal is assembled on the front of the indoor unit. The terminal of the unit is serially connected by P-LAN line to the outdoor unit.

In the control software all the regulation necessary to grant the operation and the security of the machine have been implemented, and by the terminal you can monitor the function of the unit and set the parameters of operation preference (summer/winter setpoint...). Some example figures to use the command and the machine will be reported below.

17.1 Fixing of the panel

The panel can be fixed:

- directly on the wall through the screws and the fischer supplied with the kit (optional version supplied on demand).

To fix the panel proceed as shown:

- fix the back box (A) to the standard box or to the wall (Pic. 2);
- connect the phone cable to the panel;
- fix the front (B) to the back box (A) by the screws supplied with the kit;
- instal the snapframe (C).

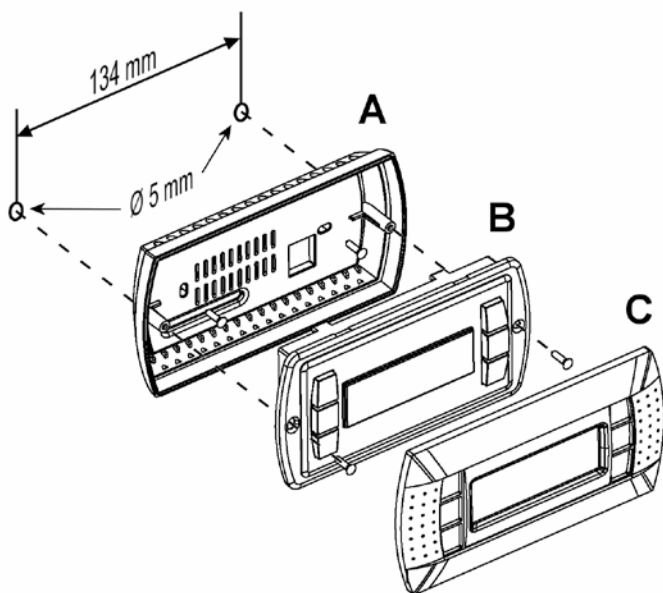

(Pic. 2)

17.2 Measures of unit command

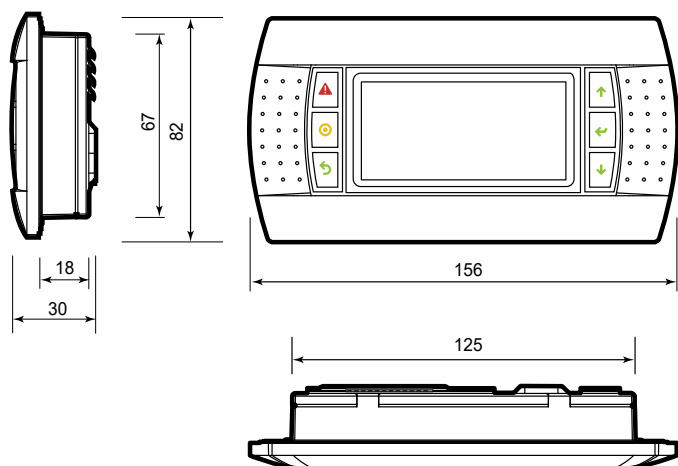

17.3 Menu overview

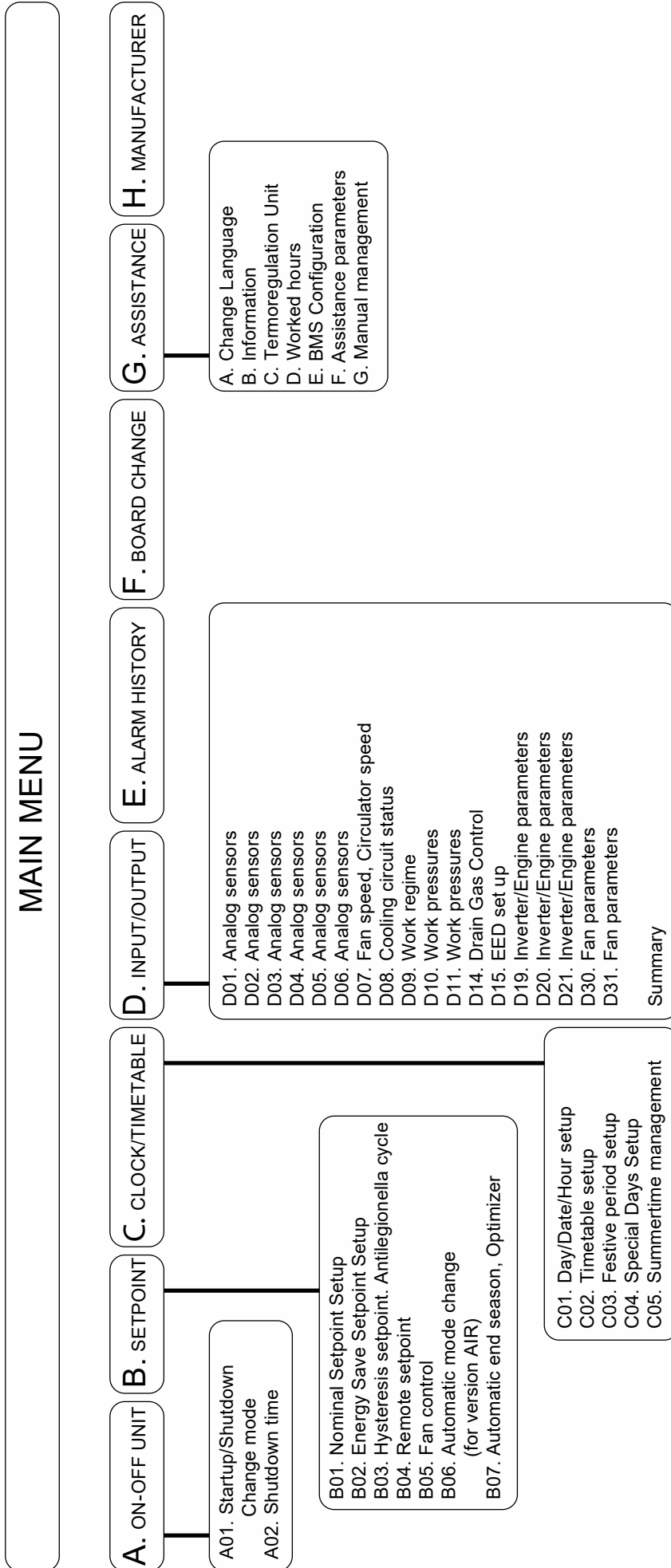

17.4 Terminal buttons

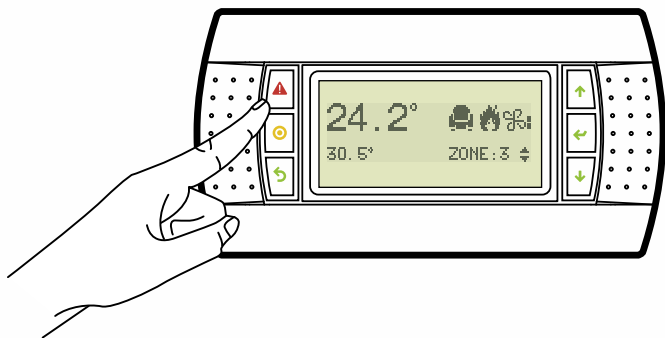

	-Alarm	List of active alarms.
		Enter the main menu tree.
		Previous mask.
	-Up	Scroll a list up or increase the value visualized on the display.
	-Down	Scroll a list down or decrease a value visualized on the display.
	-Enter	Enter the selected submenu or confirm the set value.

17.5 Terminal display

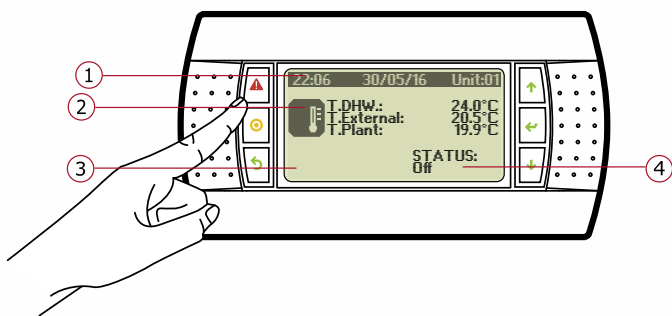

- 1 - indication on date, hour and unit connected.
 2 - main sizes and active request

	No active requests
	Hot water active request
	Hot water request from primary circuit
	Cold water request from primary circuit
	Total recover: DHW demanded + cold water from primary circuit

3 - Main active actuators

	Contemporary ignition of compressor/s activated
	Domestic hot water heating demanded
	One of the pumps of the system is on, except for pumps solar collectors
	Solar collectors installed and active
	Integration system (resistance or boiler) is working. If the icon "solar collector", just this one is visualized.
	Defrosting, instead of the 2 icons above

4 - Unit condition

The unit can be in the following condition:

- OFF
- ON
- ENERGY S.
- AUTO-OFF
- AUTO-ON
- AUTO-E.S.
- Din-OFF
- BMS-OFF
- ALARM-OFF
- PROTECT
- AUTHOMATIC BOILER MANAGEMENT IF DEMANDED

OFF

The machine is in standby: the frost protection stay active (inside circulator activation and, if demanded by too cold outside temperature, compressor activation) contrary the regulation according to system demand isn't active.

ON

All functions are active and the machine manage following the demand of the system.

ENERGY S.

All functions are active and the machine manage according to setpoint "reduced" (settable in the mask B02, see below). It allows to save energy.

AUTO-OFF

The machine manages according to timetables set (mask C02) and following the nominal setpoint (settable in the mask B01). The machine is OFF.

AUTO-ON

The machine manages according to timetables set (mask C02) and following the nominal setpoint (settable in the mask B01). La macchina si trova in stato di ON.

AUTO-E.S.

The machine manage according to timetables set (mask C02) and following the setpoint of Energy Saving (settable in mask B02).

Din-OFF

The machine is turned off by an input digital contact (if provided).

BMS-OFF

The machine is turned off by a supervisor BMS (if provided).

ALARM-OFF

The machine is in OFF because of an alarm.

PROTECT

Frost protection system for cold outside temperature and system temperature too low: the compressor is active 40°C system temperature is reached









AUTHOMATIC BOILER MANAGEMENT IF DEMANDED

The operation of the boiler is automatically managed by the heat pump control.

17.6 Main menu

To enter in the menu press the button **Prg**. Press the buttons **↑** and **↓** to surf in the menus. At the end of the operation, press **Esc** to come back to the main screen.

The 8 menu as follows:

A.		On-Off unit
B.		Setpoint
C.		Clock/Timetable
D.		Inputs/Outputs
E.		Alarm history
F.		Board change
G.		Assistance
H.		Costructor

17.7 Menu ON-OFF

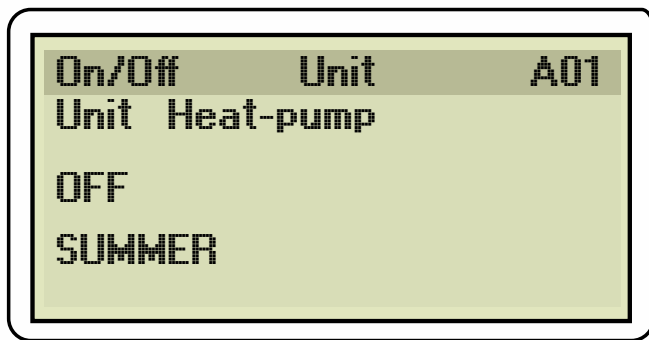

Mask A01: set condition and operation mode. When OFF is set in this menu, it will be always conditioned (es. frost protection).

Mask A02: Turn off the pump without conditions for a certain period of time. Expired the time the function is enabled again A01.

17.8 Menu SETPOINT

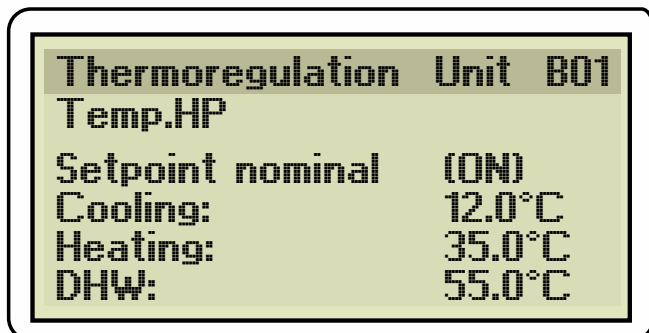

Mask B01: Variation of nominal setpoints.

Mask B02: Variation of Energy saving setpoints. We suggest to use Energy saving during the night or during long absences from home. To reduce the unit consumption it is

suitable to use the climate curve instead of setting the Setpoint, because it allows a continue erogation.

Mask B03: activation of antilegionella cycles programs. Fro the setpoint we suggest 70°C as per manufacturer data.

Mask B05: choice of fan operation mode.

It is possible to choose between the following states:

- **POWERFULL:** it is the most efficient condition, but it involves also the noise of the major fan.
- **NORMAL:** it is the condition of operation set by the manufacturer, it allows a good compromis between efficiency and noise.
- **QUIET1 - QUIET2 - SILENT:** in these conditions of operation the fan is slowed respectively of 10, 15, 20 percentage points. Such conditions allow to work with a more and more reduced noise. We underline that, setting this function, the efficiency of the machine is more and more reduced too

Mask B06: Just in AIR version. Authomatic mode change to pass from cooling to heating mode defining a comfort zone where none of 2 modes are active. To the function be activated the difference between the setpoints of cooling and heating has to be the same as the Delta Comfort. Besides it allows to set the operation mode of the inside fan. The inside fan can follow the demand (compressor speed) low, medium or high or check the condensation.

Mask B07: Automatic Season End. You have to set the daily average temperature above which the heating function turns off and the daily average temperature below which the heating function turns on; if present the domestic function stay active.

- **En. autoswitch:** activate and deactivate the function.
- **HP disable Ext. T.:** the daily average temperature above which the heating function turns off
- **HP enable Ext. T.:** the daily average temperature below which the heating function turns on.
- **Average Ext. T.:** the actual daily average temperature.

Mask B08: optimizer management. The optimizer is an algorithm permitting to store energy exploiting the thermal inertia of the building when the conditions are better.

- **Active Optimizer:** the function is enabled or disabled.
- **Final Setpoint:** Target value of the heat pump with Delta Optimizer.
- **Delta Optimizer:** Delta (positive or negative) due to the optimization algorithm.
- **Imfluence:** minimum value (negative delta) and maximum (positive delta). This function is used to limit optimizer influence if necessary.

Mask B09: set an hysteresis in turning off. Once Setpoint reached, the machine doesn't turn off but continues working at minimum until to reach this target on the setpoint. In the meantime the demand increase again (ex. demand from the domestic) the compressor comes back to the operation range required.

17.9 Menu Clock/time slots

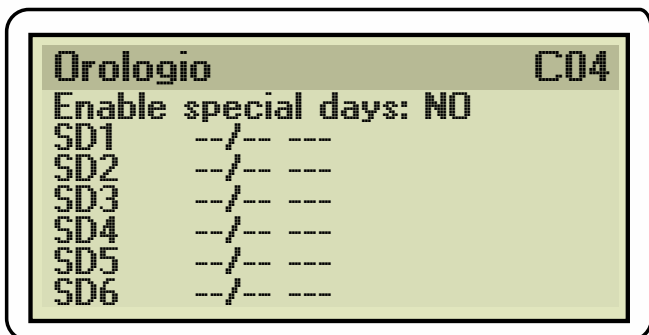
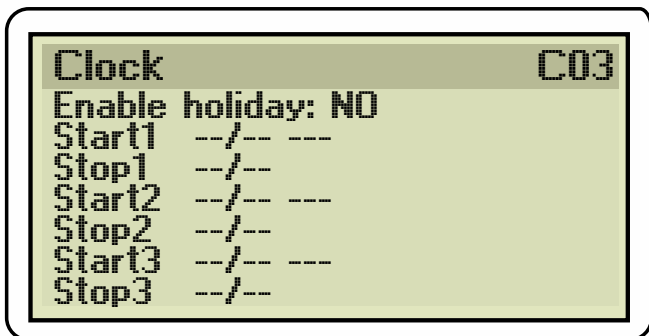
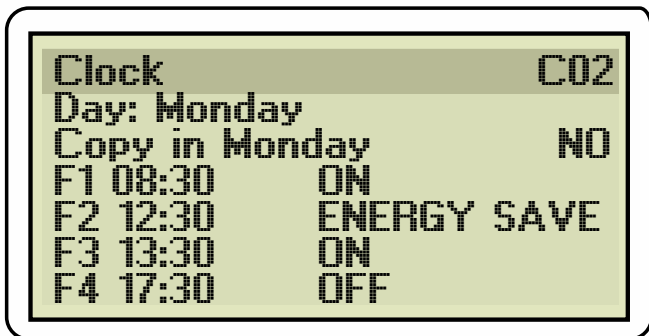
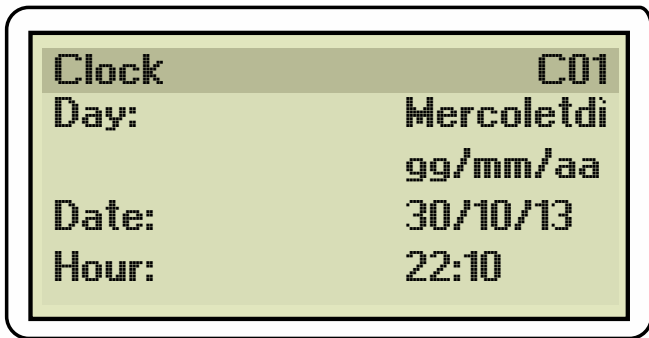

Mask C01: Date and hour setting.

Mask C02: Timetable setting.

To have access to timetable modification set from the menu ON-OFF the states OFF or AUTO.

Press the button to chose the day when you want to set the timetable.

Use the buttons and to change the visualized value.

Confirm with the button .

Press twice the button to pass to hour setting:

- F1: timetable from 00:00 of the selected day, to the timetable set in F1.
- F2: timetable from the timetable set in F1 to the timetable set in F2.
- F3: timetable from the set timetable in F2 to the set

timetable in F3.

- F4: timeslot from the timetable set in F3 to the set timetable in F4.

After you have entered the timetable in the first slot, confirm with to set the wanted operation mode in the slot mentioned (choose between ON - OFF- ENERGY SAVE).

Confirm the choice with and proceed with the setting of the other time slots.

To set the timetable in the other days press the button and proceed as previously explained.

Contrary it is possible to copy the setting of different days: once entered into the mask C02

- press the button to have access to the choice of the day you want to copy
- use then the buttons and to chose the day
- Confirm with the button
- With the buttons and choose the day when you want to copy the time slots
- Confirm with
- With the button choose YES and confirm with

Mask C03: Enable three periods with pre-set operation.

- Press and to enable/disable the period/s.
- Confirm with to have access to the choice of the starting day of the special period.
- Use the buttons and to choose the starting day
- Confirm the choice with
- Choose the operation mode with the buttons and
- Confirm with the button
- Use the buttons and to chose the final day
- Confirm your choice using
- Repeat the same actions to set possible remaining periods.

Press **Esc** to come back to menu.

Mask C04: Enable a pre-set operation 6 different days at last.

- Press and to enable/disable the special day/s
- Confirm with to have access to the choice of the starting day of the particular period.
- Use the buttons and to choose the starting day
- Confirm your choice with
- Choose the operation mode with the buttons and
- Confirm with the button
- Repete the same actions to set the possible remaining special days

Press **Esc** to return to the menu.

Mask C05: Enable the authomatic transition from winter time to summertime. At the beginning the parameters are set by the manufacturer.

17.10 Menu Inputs/Outputs

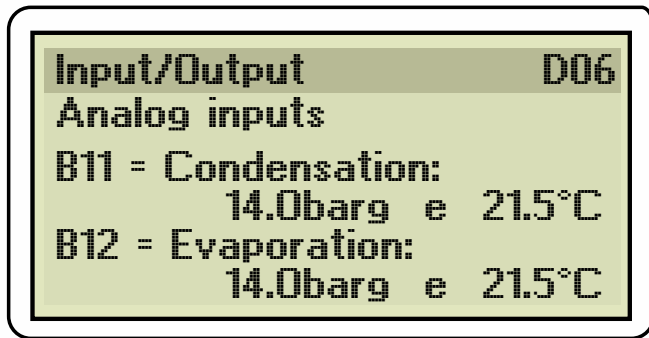

Having access to this menu it is possible to read several values. From the screen D01 to the screen D06 it is possible to read the following probes:

- B1:** difference between the primary flow and the return liquid temperature from the plate heat exchanger: it represents the SUBCOOLING in the heat pump (heating) operation.
- B2:** temperature of the probe to insert in the puffer of the system. If the function NoPuffer is activated (from the Assistance menu) the probe B2 is ignored.
- B3:** Domestic temperature probe to be entered on the top of the domestic boiler. If there is one tank working both on the system and on the domestic, just a probe has to be used.
- B4:** return temperature of the system.
- B5:** flow read by the flowmeter.
- B6:** compressor head temperature
- B7:** flow temperature probe of the plate heat/refrigerant gas exchanger.
- B8:** Outdoor air temperature.
- B9:** compressor flow temperature.
- B10:** compressor suction temperature.
- B11:** condensation pressure and temperature.
- B12:** evaporation pressure and temperature.

Mask D07: management of fan speed and Circulator speed.

Mask D08: state of the cooling circuit :percentage of the electronic expansion valve opening, B10, B12.

Mask D09: work regime.

- Capacity demanded.
- Real capacity.
- Compressor speed.
- Waiting time ON: minimum time occurring between 2 turning off, or the time necessary to equalize the pressure of high and low to the right starting value.

Mask D10: work zone in the envelope and the countdown of the alarm "out off envelope".

Mask D11: information about pressures.

- difference between pressure of high and low
- relation between pressure of high and low
- alarm "low delta P" countdown

Mask D14: temperature of the compressor drain, zone and state of the envelope.

Mask D15: overheating of drain compressor and relative type of heating control.

- SSH = Suction Super Heating
- DSH = Discharge Super Heating

Mask D19: Parameters Inverter/Engine

Mask D20: Parameters Inverter/Engine

Mask D21: Parameters Inverter/Engine

Masks D30, D31: masks regarding the fan outside battery. You can find the rpm and the instant power.

Mask D32: performances.

- flow
- delta T (B7 - B4)
- Electrical power
- thermal power
- COP

Mask D33: summary of unit parameters

16.11 Menu alarm history

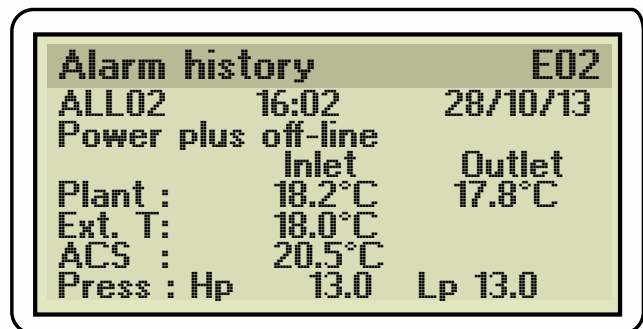

In this menu it is possible to visualize the alarms caused by a possible intervention of the protection. The alarms list is in the chapter 13.

17.12 Menu board change

the menu board change allows to visualize other heat pump/s when they are connected by pLAN and the settings of the electronic board/panel allow it.

17.13 Menu assistance

The menu Assistance has a submenu structured as follows:

- a. Language change
- b. Information
- c. assistance inputs/outputs
- d. Worked hours
- e. Config. BMS
- f. Param. Assistance
- g. Manual management

A. LANGUAGE CHANGE

This menu allow to change the language, where present.

MaskGa01

Possible languages: Italian, English, German and French.

B. INFORMATION *

This menu contains masks where there are information concerning the software, control board, valves and nverter, reserved to the technical assistance.

C. INPUTS /OUTPUTS ASSISTANCE

This menu contains the masks of inputs and outputs reserved to the technical assistance.

Gc16: visualize in steps and percentage the opening of the injection valve.

Gc17:	inverter status.
Gc18:	inverter status.
Gc22:	inverter status.
Gc23:	inverter status.
Gc24:	digital inputs
Gc25:	digital inputs
Gc26:	digital inputs
Gc27:	digital outputs
Gc29:	digital outputs
Gc32:	fan status

D. WORKED HOURS

This menu allows to monitor the working time

Mask Gd01: In this mask total working hours of the heat pump are visualized.

Mask Gd02: In this mask the defrost numbers made by the machine during the heat pump operation are visualized.

E . CONFIGURATION BMS

This menu allows to set a communication protocol of the "BMS" port of the control electronics. This menu is protected by a password. Only the authorized staff can enter.

F . ASSISTANCE PARAMETER

This menu is password protected. Only the authorized staff can have access.

- Hour meter settings
- probes calibration
- thermoregulation
- user default/password change

a. HOUR METER SETTINGS

Reserved to authorized staff

b. PROBES CALIBRATION

Gfb01: probes calibration B1 and B2

Gfb02: probes calibration B3 and B4

Gfb03: probes calibration B5 and B6

Gfb04: probes calibration B7 and B8

The position of B8 sensor may affect the operation of your heat pump, therefore only for sensor B8 it is possible to choose:

- on board:** the probe is set on board
- remote:** the remote probe is set

Gfb05: probes calibration B9 and B10

Gfb06: probes calibration B11 and B12

Gfb07: offset S1, S2

Gfb08: offset S3, S4

Gfb09: probes calibration B2 and B3 enabled and imported

c. THERMOREGULATION

Mask Gfc01: it sets the presence of a puffer and the auxiliary integration.

- puffer presence:** (yes - no)
- system integration:** (none - boiler)
- domestic integration:** (none - boiler)

Mask Gfc02: Configuration request integration parameters.

It allows to define the thresholds of auxiliary integration intervention (boiler / electric heater) to the heating based on the request (the ability to reach the set point in a given time interval) and on its proportional part.

It is defined the working condition to which the heat pump requires help from the integration, namely the condition of "crisis".

- ON-Request:** it represents the request generated by PID of the reached water that activate the integration.
- ON-Propor.:** it represents the distance from the set, in percentage, over that activate auxiliary integration.

For example: the percentage of the proportional band Hc06 as per factory default is set at 10. The 60% of 10 is 6°C . It represents the proportional enabling the integration of auxiliary heating. Higher this value is it means the machine is far from set. If this value was low and the previous higher, the boiler could start even if it isn't necessary, for example if the machine stayed near the set (low proportional) for long time (high integral pushing), no reaching it. In qthis case the machine would be a little subsized but it could heat the water in any case, without a necessary intervention of the boiler.

The combination of the two previous parameters, then, identifies when the machine is really in crisis and needs integration. Happening both conditions the integration is active.

- OFF-Propor.:** it's the percentage of the proportional band Hc06, that as default is set at 10, under that the integration shut down.
- OFF-Diff.:** Degrees the integration has to produce more on Setpoint set on the heat pump.

Mask Gfc03: integration activation in case of need (heat pump in "crisis").

- Setpoint act.:** external temperature value under that the boiler is enabled to start if the machine is considered in crisis (parameters in Gfc02)
- Differential:** deltaT positive, that is the integration is enabled until the external temperature reaches a temperature equal to Setpoint+Differential.
- Boiler activation delay:** verify previous conditions, the boiler is activated if they stay for the time set.

Mask Gfc04: integration activated according to the outside temperature.

In this case the integration started when the outside air temperature falls below the set value. Once activated the auxiliary source, it works in conjunction with a heat pump, unless it is not been set her to turn off.

Integration remains active until it reaches the set water setpoint, although the air temperature rises above the value set.

- Setpoint act.:** external temperature value that enable the heating control, heating independent from other factors
- Differential:** deltaT positive, that is the integration is enabled until the external temperature reaches a value equal to Setpoint+Differential.
- Turn off compressors:** it allows to turn off the heat pump under the defined temperature in Setpoint act. : the integrated system totally replaces the heat pump.

Mask Gfc05: integration to HDW based on the external temperature.

- Diff.on HWD:** value of external temperature over that the integration HWD system turns on, it stays on until the reaching of the set

value in Diff.off HWD.

- **Diff.off HWD:** temperature threshold under that integration system for HWD turns off.
- **Delay ON:** activation delay of the integration once respected the conditions above.

Mask Gfc06: setting of the temperature curve.

- **Regulation of temp. primary system:** the choice is between the wording "FIX POINT" and 3-POINTS CURVE:

FIX POINT: the machine adjusts according to the setpoint set, every temperature of the external air

3-POINTS CURVE: it is the setting suggested by us. It's impossible directly set the three temperature points external/set point temperature, the logic builds a broken line as the following figure:

Heating curve setting

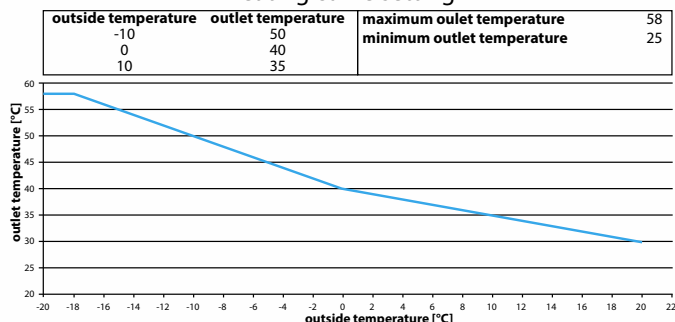

It is also displayed the nominal active Set.

Changing the nominal Set from the menu SETPOINT (B01) the entire climate curve will have a translation positive or negative according to the Set. (for example, changing the nominal set from 35°C to 33°C the whole curve will lower 2°C in every working condition).

Mask Gfc07: reserved

Mask Gfc08: circulator management disabled puffer.

- **Delay OFF:** when the compressor stops, the circulator works for the number of seconds set
- **start delay:** time in minutes from the turning off of the compressor to the start up of the function;
- **Pump ON time:** circulator operation time;
- **Pump OFF time:** circulator stop time

Maschera Gfc15: reset antifreeze alarm.

- **Reset antifreeze alarm primary circuit:** it allows to establish if the rearming is manual or automatic.
- **Manual:** (default) the machine restarts only if the user resets resetta manually the alarm.
- **Auto:** the machine restarts automatically when the flow temperature is increased to the value Set_alarm_antifreeze + Diff_Activat

Mask Gfc16: circulator operation mode.

- **It actives pump primary circuit:** it is possible to choose "ON DEMAND" e "ON UNIT".
 - **On demand:** the circulator just starts if required by the heat pump (that is when there is a request for the ignition of the compressor or to manage possible antifreeze alarm).
 - **On unit:** the circulator starts when the unit is ON.

- **Pump for antifreeze:** it enables the activation of the pump (circulator) for the function antifreeze winter.

Mask Gfc17: Setpoint on the system temperature for the activation of the antifreeze that activates the circulator.

Set antifreeze pump primary circuit: temperature set that activates the winter antifreeze protection. When the flow temperature (sensor B7) is lower than the value set hear, the circulation pump is activated to keep a continuous flow in the hydraulic lines.

- **Diff. Activat. antifreeze pump:** the pump, activated by the antifreeze protection, continues working until the flow temperature is equal to Set+Diff.

Mask Gfc18: Setpoint on the external temperature for antifreeze activation that activates the circulator.

- **Setpoint:** value of external temperature under that winter antifreeze function is activated. That is it starts the circulator for the recirculation of the water in the pipelines.
- **Diff.:** differential of temperature that, added to the setpoint, determine the temperature of the external air that blocks the winter antifreeze function when it is active.
- **Time ON and Time OFF** represent the cycle of activation and shut down of the heat pump during the function of winter antifreeze protection. Time ON and OFF are expressed in minutes

NB: the setpoint of these screens (17 and 18) depends on the type of installation. For example with air sensor B8 exposed to the sun an incorrect value could be read and nullify the function. If the sensor is exposed to the sun we suggest to install a remote sensor and install it in a shady place.

Mask Gfc20: resetting set overheating reset .

- **Reset overheat. alarm primary circuit:** it permits to establish if the resting is manual or automatic.
 - **Manual:** (default) the machine restarts only if the user resets the alarm manually.
 - **Auto:** the machine restart automatically when the flow temperature is decreased to the value Set_alarm_overheat-Diff_Activat.

Mask Gfc21: selection for the setting of the mode (winter or summer) through user panel or remote external switch (digital).

- **Summer/Winter selec. Season from:** it is possible to choose between "KEYBOARD" (operator panel) or "IN. DIG. 1" . In this case you have to consider it isn't enough to manage the commutation summer/winter but also the production of the domestic hot water if the unit has also to produce DHW. About this see documents relevant to the function no puffer in the end of the manual.

Mask Gfc22:

- **Enable protection:** it allow to enable or not the function winter antifreeze protection that activates the compressors when the plate heat exchanger reaches a temperature too low.

If the previous parameter is active, also the following parameters become editable:

- **Unit ON:** flow water temperature value (sensor B7) that activates the function
- **Unit OFF:** flow water temperature value (sensor B7) that stops the protection function.

Mask Gfc23: enabling external reports

- **It enable warning reports on output NO7:** it allows to enable the digital output NO7, to whom it could be connected for example a notification led, when the machine is in alarm for minor causes.

Mask Gfc25: defrosting setting.

- **Fan consumption:** fan consumption in W sized by the electronic and used to start the defrosting procedure.
- **Start up delay:** start up delay of the compressor after that it is allowed the defrosting start up. To avoid that the defrost starts just after the ignition of the compressor, situation where you can have the conditions of the defrost start up, due to the start up dynamics.
- **Fan delay:** waiting time before of starting the defrost
- **Defrost delay with temperature differencies:** Waiting time for the activation of the defrost for delta T.

Mask Gfc27: parameters defrost.

- **En oil defrost:** element that allows to enable the returno of the oil through defrost cycle. If enabled and if the unit required the return of the oil normal defrost procedure is activated with maximum settable speed with the following parameter "Defrost Speed".
- **Low speed defrost:** if at the moment of defrost start up the compressor had a lower speed than the Thershold the compressor speed during the defrost will be defrost speed.

Mask Gfc34: drip parameters.

- **Drip manag.:** it enables the operation of the fan before the inversion of the 4-way in output from the defrost cycle, that rotating at a high rpm promotes the disposal of the water drops still in the battery.
- **Fan Dripping Speed:** it is the speed where the fan is forced il ventilatore in this specific phase of the defrost process.
- **Fan reverse Dir:** it allows to enable or not the reversing of the rotation direction of the fan. If enabled, the dripping is made with a fan that turns in the opposite.

Mask Gfc37: defrost parameters.

- **Integration of the system during the defrosting.:** It enables the integration generator to the system (boiler or electric resistance).
- **Def. end max time exceeded:** it allows to choose between HISTORY and HISTORY+ALARM, that is to choose the registration/reporting mode of the event "the defrosting is finished because the maximum time is exceeded".

Mask Gfc50: It allows to enable the condensate drain in fix or intermittent mode in base on the external temperature.

- **Res.drain cond.:** it enables the activation of the resistance for the condensate drain.
 - **ALWAYS ON (Set1):** in this condition, the resistance is always active under this parameter
 - **Set:** value of temperature reached that the resistance condensate drain is always active.
 - **Diff:** differential of temperature. When the xternal temperature is equal to Text= Set+Diff you go out form this function
- **MODE ON-OFF (Set2):** in this condition the resistance is activated under the set, at time intervals as defined from the following parameters.
 - **Set:** value of temperature reached that the function is activated.
 - **Diff:** differential of temperature. When the external temperature is equal to Text= Set+Diff you go out from this function
 - **T.On:** time of on of the resistance in minutes.
 - **T.Off:** time of off of the rsistance in minutes.

Mask Gfc51: limitation in power consumption.

- **En.Watt limit rps:** Enabling of maximum allowed speed limitation to compressor for work of the effective consumption in watt.
- **Thr.:** maximum threshold reachable by the total consumption (compressor, fan, auxiliary, circulator, auxiliary...)
- **Band:** Band in which the value of instant consumption can swing, but always staying under the threshold set
- **Fan:** Consumption value read by the fan. The reading is possible only thanks to the protocol od communication modbus (protocol to communicate) RS 485 (physic network constituted by a certain number of wires), it is set in one to read the effective consumption value
- **Pump:** Consumption value of the circulator. Now it is a constant value and equal to the maximum consumption.
- **Aux:** Consumption values of the auxiliaries. Set equal to 20 W costant.
- **Update time:** interval of time passed that you have the update, up or down, if all the conditions aallow it, the variable that contains the maximum speed allowed by the compoessor.
- **Update rps:** positive or negative increasing of the variable that contains the maximum speed available by the compressor.

Operation:

- if Thr is < the current consumption of the unit the limitation of the maximum rpm of the compressor starts decreasing of "Update rps" every "Update time"
- if the current consumption is included between (Thr-Band) and Thr correction actions aren't made
- if the current consumption is < than (Thr-Band) the compressor is free from binds (the maximum speed allowed can increase)

Mask Gfc55: it enables the control of the circulator in PWM.

- **Enabling:** yes/no
- **Mode of use:**
 - **mode Delta T (B7-B4):** it tries to keep in automatic the delta set by the circulator slowing down or accelerating.
 - **RPS:** the circulator follows the rpm of the compressor following the below settable curve.
- **Setpoint:** the degrees you want to keep if the function is enabled in the mode Delta T

Mask Gfc56: it allows to change the intervention threshold of defrosting.

- **Model:** fan model present in the heat pump.
- **Amp:** parameterization defrost.

d. DEFAULT USER / CHANGE PASSWORD

Mask Gfd01: it allows to change the password of the access to assistance menu.

- **Cancel history alarms:** it cancels completely the history of the alarms.
- **Insert a new password:** it allows to replace the password of the access to the assistance menu

G . MANUAL MANAGEMENT

This menu is protected by a password. Only the authorized staff can have access.

Mask Gg01: It allows to force in manual (MAN) some digital outputs so to verify the correct electrical connections. Refers to the guide supplied with the unit for possible other digital outputs presents

- **N04 primary pump:** it allows to activate the circulator.
- **N05:** it allows to activate the condensate drain heater.
- **N09 DHW 3-way valve:** the 3-way valve for DHW production if present.

Mask Gg02: it allows to force the fan at the wanted speed, selectable by required power.

- **Fans speed:** it activates the manual management of fans speed.
- **power required:** % active if manual management is enabled.

Mask Gg03: manual or automatic management of the expansion valve.

- **It enables valve manual position:** it enables the manual management.
- **Valve manual position:** if the manual management is activated, it shows the opening of the valve measured in steps.

USE VERY CAREFULLY, TO AVOID TO BREAK THE COMPRESSOR, CONTRARY THE WARRANTY WILL EXPIRE.

Mask Gg04: injection valve manual or automatic management.

- **It enables valve manual position:** it enables the manual management.
- **Manual valve position:** if the manual management is active, it shows the valve opening in steps.

Mask Gg05: manual or automatic management of the heat pump.

- **CH/HP Request:** it enables speed manual management of compressor for the heat pump in heating and cooling.
- **speed:** if the manual management is active, it shows the compressor speed for the heat pump

- **DHW Request:** it enables speed manual management of the compressor for DHW production.

- **speed:** if manual management is active, it shows the compressor speed for the DHW.

Mask Gg06: it enables the defrosting cycle.

- **It enables the defrosting cycle:** it enables a defrosting cycle.

Mask Gg07: management of oil recover

- **It enables oil forcing:** it enables a forcing in oil recover cycling.
- **En. manual PWM:** it allows to force circulator power.
- **PWM request:** it sets the speed needed by PWM in manual operation.

Mask Gg08: integration management.

- **N06 Plant Integr.:** auxiliary heater output (es. boiler).
- **N08 DHW Integr.:** auxiliary heater output for DHW (es. electric boiler).

Mask Gg09: only in AIR version. Management of winter fan.

- **Fan speed:** it enables the manual management of fan speed.
- **Power required:** % active if it is enabled in manual management.

Mask Gg10: this mask allows to manage screed dryer function.

- **Start cycle:** set the function ON or OFF.
- **Elapsed time:** It shows the elapsed time after the activation of the function.
- **Start temperature:** the starting temperature of the function.
- **Target temperature:** the target temperature of the function. The temperature increases linearly.
- **Raise hours:** the amount of hours the function must use to raise from starting temperature to target temperature.
- **Stabilise hours:** the amount of hours the function must stay in target temperature.
- **Cool down:** the amount of hours the function must use to cool down from target temperature to start temperature.

Mask Gg11: this mask allows to ignore the oil temperature control of the compressor.

Maschera Gg12 initialization: this mask is used to initialize the heat pump. The initialization erases all data previously saved in the heat pump.

18 Alarms

Alarm code	Visualized message	Reset	Delay	Relay	Action
ALA01	Probe B1 broken or disconnected	Automatic	60 sec	Yes	Stop the machine
ALA02	Probe B2 broken or disconnected	Automatic	60 sec	Yes	If there is a geothermal modulating pump it is set at the maximum speed
ALA03	Probe B3 broken or disconnected	Automatic	60 sec	Yes	Stop the regulation of the domestic circuit
ALA04	Probe B4 broken or disconnected	Automatic	60 sec	Yes	Stop the machine
ALA05	Probe B5 broken or disconnected	Automatic	60 sec	Yes	Stop the pump of the solar collector
ALA06	Probe B6 broken or disconnected	Automatic	60 sec	Yes	Stop the functions enabled by the outside probe
ALA07	Probe B7 broken or disconnected	Automatic	60 sec	Yes	Stop the machine
ALA08	Probe B8 broken or disconnected	Automatic	60 sec	Yes	Stop the pump of the solar collector
ALA09	Probe B9 broken or disconnected	Automatic	60 sec	Yes	If Siam compressor stops the compr.
ALA10	Probe B10 broken or disconnected	Automatic	60 sec	Yes	If there is the electronic expansion valve it stops the machine
ALA11	Probe B11 broken or disconnected	Automatic	60 sec	Yes	Stop the machine
ALA12	Probe B12 broken or disconnected	Automatic	60 sec	Yes	Stop the machine
ALB01	Position: ID3 High pressure	Manual	Immediate	Yes	Stop the machine
ALB02	High pressure of the compressor 1 from transducer	Manual	Immediate	Yes	Stop the machine
ALB03	Low pressure of the compressor/s from transducer	Automatic (par. Hc05)	At the start: 40s (par. Hc03) at regime: 10s (par. Hc04)	Yes	Stop the machine
ALC01	Position: ID2 Thermal compressor 1 or allarm inverter	Manual	Immediate	Yes	If 1 comp. enabled: stop the machine If 2 comp. enabled: stop comp.1 (if comp. 2 is available)
ALC02	Position: ID9 Thermal compressor 2	Manual	Immediate	Yes	Stop comp.2 (if comp. 1 is available)
ALC03	Alarm envelope: 0: Max.rel.compr. 1: Max.press.drain 2: Power limit 3: Max.press.suc. 4: Min.rel.compr. 5: Min.diff.pressure. 6: Min.press.drain 7: Min. press.suc. Compressor off for working out of envelope (only with compressor Siam)	Manual	60 sec (par. H1b14)	Yes	Stop the compressor
ALC04	Alarms missing start of the compressor (only with compressor Siam)	After 5 times per hour it becomes manual	60 sec (par. H1b11)	Yes	Stop the compressor
ALC05	Max.drain time (only with compressor Siam)	After 3 times per hour it becomes manual	Immediate	Yes	Stop the compressor
ALC06	Delta pressure < minimum request for the return of the compr. oil (only with compressor Siam)	Automatic	120 sec (par. H1b12)	Yes	Stop the compressor

Alarm code	Visualized message	Reset	Delay	Relay	Action
ALP01	Position: ID1 Flow switch geothermal circ. water	After 5 times per hour it becomes manual	At the start: 15s (par. Hc15) at regime: 5s (par. Hc16)	Yes	Stop the machine at maximum time reached
ALP02	Position: ID4 Thermal pumps	Manual	Immediate	Yes	Stop the machine
ALP03	Positions: ID10 Flow switch primary circuit water	After 5 times per hour it becomes manual	At the start: 15s (par. Hc12) at regime: 5s (par. Hc13)	Yes	Stop the machine at maximum time reached
ALP04	Position: ID5 Thermal pump solar circuit	Manual	Immediate	Habilitable (Gfc01)	Stop the pump of solar collector
ALR01	Position: ID7 Alarm boiler/ resistance integr. system	Automatic	Immediate	Habilitable (Gfc02)	Stop boiler/ resistance operation primary circuit integration
ALR02	Position: ID6 Thermic boiler/resistance DHW from digital input	Manual	Immediate	Settable (Gfc03)	Stop operation boiler/resistance integration DHW
ALF01	Position: ID1 Thermic fan	Manual	Immediate		Stop the machine
ALT01	Threshold reached worked hours by the compressor 1	Manual	Immediate	Settable (Gfa01)	Only signal
ALT02	Threshold reached worked hours by the compressor 2	Manual	Immediate	Settable (Gfa01)	Only signal
ALT03	Threshold reached worked hours by the geothermal pump	Manual	Immediate	Settable (Gfa01)	Only signal
ALT04	Threshold reached worked hours by primary circ. pump	Manual	Immediate	Settable (Gfa01)	Only signal
ALT05	Reached threshold worked hours pump DHW	Manual	Immediate	Settable (Gfa01)	Only signal
ALT07	Threshold reached worked hours solar pump	Manuale	Immediate	Settable (Gfa01)	Only signal
ALT08	Threshold reached worked hours outside battery fan	Manual	Immediate	Settable (Gfa01)	Only signal
ALU01	Geothermal frosting protection exchanger	Manual (par. Gfc28)	Immediate	Yes	Stop the machine
ALU02	Frosting protection primary exchanger	Manual (par. Gfc32)	Immediate	Yes	Stop the machine
ALU03	Overheating exchanger	Manual	Immediate	Yes	Stop the machine
ALW01	Threshold reached high domestic water	Automatic	60 sec	Habilitable (Gfc01)	Only signal
ALW02	Threshold reached maximum domestic temperature at solar collector	Automatic	60 sec	Yes	Only signal
ALW03	Exceeded max. time to defrosting end	Automatic	Immediate	Yes	Only signal
ALD01	Alarm EEPROM	Manual	Immediate	Yes	Stop the machine
ALD02	Probe EVD EVO broken or disconnected	Automatic	Immediate	Yes	Stop the machine
ALD03	Engine error EEV	Manual	Immediate	Yes	Stop the machine
ALD04	Low overheating (LowSH)	Manual	Immediate	Yes	Stop the machine
ALD05	Low suction temperature	Manual	Immediate	Yes	Stop the machine
ALD06	Evaporation low temperature (LOP)	Manual	Immediate	Yes	Stop the machine
ALD07	High evaporation pressure (MOP)	Manual	Immediate	Yes	Stop the machine
ALD08	High condensation temperature (HiTcond)	Manual	Immediate	Yes	Stop the machine
ALD09	Driver offline	Automatic	Immediate	Yes	Stop the machine
ALL01	Device Power+ n. 1 Offline	Automatic	30 sec	Yes	Stop the machine
ALL02	Alarms Power+ n.1 0: No error 1: Overpower 2: Overp. engine 3: Overvoltage 4: Undervoltage 5: Overtemperature 6: Undertemperature 7: Overpower HW 8: Overtemp. engine 9: Reserved 10: Error Cpu 11: Param. default 12: Undulation DC bus 13: timeout com.ser. 14: Error thermistor 15: Error Autotuning 16: Drive disabled 17: Engine phase missing 18: Broken fan 19: Engine stalling	Manual	Immediate	Yes	Stop the machine

The letter preceding the number has the following meaning

A	"AIN" Physic probes broken uPC
B	"Boh" Alarms blocking the Circuit, High-Low pressure..
C	"Compressor" Thermic, envelope
D	"Driver" Electronic valve
E	"Expansion" Alarms uPCe
F	"Fan" fan
G	"Generic" general alarm, Clock broken, HW, Memory
H	"Humidifier" humidifier
I	"Fancoil" alarms coming from and hydronic net
M	"MP-BUS" / Belimo
O	"Offline" Offline supervisor, offline pLAN
P	"Pumps" Pumps flow switches, pumps thermic
Q	"Quality" HACCP, Consumptions
R	"Remote" Various alarms from digital inputs
S	"Serial probe" Serial probes
T	"Timing" Warning maintenance
U	"unit" Alarms blocking the unit
V	"VFD" Alarms inverter
W	"Warning" generic
X	Defrosting
Y	Climate

18.1 Alarms resolution

Alarm code	Causes	Solution proposed
ALB01	Condensation high pressure, the most of times this alarm is caused by the too high set of the water produced both in heating than in DHW. Other very frequent causes are: the wrong positioning of regulation probes (B2 and B3) compared to the flow of the unit and the insufficient water flow to plate heat condenser.	1) place the probes B2 and/or B3 at the same height as the input flow accumulation of the machine.
ALB02	See ALB01	See ALB01
ALB03	The low pressure from transducer can be connected to dynamic inside the machine. But it can also be symptom of a malfunction of the transducer or a refrigerant loss.	If the alarm is frequent 2/3 consecutive times in 4-6 hours inspect the unit with a leak detector and contact the assistance.
ALC03	Alarm envelope, the compressor is out from its field of work. In this case the reasons can be several and not listable.	We suggest at first to consider the use of the unit that can be incoherent with the work field of the unit, for example, operation DHW with outside too high temperatures. See the section "operative zone allowed" of this manual.
ALC04	The compressor can't create a minimum pressure delta in a certain interval of time, the cause can be the inertia of the system and the nearness between the temperatures of air and water	If it occurs occasionally, it's just a no serious signal permitting to the unit to keep on working.
ALP03	Flow loss in the hydraulic system, caused by air in the system, solid particles or excessive flow loss	Vent the system of all the air, regular cleaning of the system. Avoid excessive pressure loss in the hydraulic circuit, in particular avoid restrictions in the system.
ALW03	Caused by air currents cooling the coil finned during the defrosting procedure	Study a different positioning of the machine or block the wind addressed to the unit.
ALD04	Alarm which depends on the dynamics inside the machine	Contact the assistance
ALD06	Alarm which depends on the dynamics inside the machine	Inspect the unit with leak detector and contact the assistance
ALD07	Alarm which depends on the dynamics inside the machine	Contact the assistance
ALL01	Missing communication between inverter and electronic board caused by slight power surges and current or by electromagnetic fields disturbing the network	Check the counter powering the machine, avoid to overload it, check the domestic line, avoid electromagnetic fields nearby
ALL02	Missing communication between inverter and electronic board caused by strong power surges and current or electromagnetic fields disturbing the network	Check the counter powering the machine, avoid to overload it, check the domestic line, avoid electromagnetic fields nearby. The contact the assistance.

18.2 Notifications

Notification	causes
Heat Transfer Limited	It occurs when the difference between the value of the B7 and B2 probes in the case of heating operation, or the difference between B7 and B3 probes in the case of DHW production, is excessive.
Power limit temperature	It is activated if the heat pump is producing water less than 6 ° or more than 58 °. The compressor is moves to a minimum speed to avoid generating an error.
Irregular waterflow	Since the heat pump was powered, at least once a problema of flow occurred. After five of these notificatios, the next one is a flow error.

19 Declaration of conformity



Dichiarazione di conformità UE EU Declaration of Conformity EU Konformitätserklärung

La sottoscritta
The undersigned
Die Firma

Templari Srl
Via Pitagora, 20/A – 35030 Rubano (PD) - Italy
P. IVA 04128520287

conferma che l'apparecchio qui di seguito indicato risponde alle seguenti direttive CE applicabili in materia. Ogni modifica dell'apparecchio rende la presente dichiarazione non valida.

hereby certifies that the following device complies with the applicable EU directives. This certification loses its validity if the device is modified.

erklärt in alleiniger Verantwortung, dass die nachfolgend erwähnte Produkte den angeführten EC – Normen entsprechen. Bei jeglicher Veränderung an den Geräten erlischt die Gültigkeit dieser Konformitätserklärung.

Denominazione: Pompe di calore
Designation: Heat Pump
Produkt: Wärmepumpe

Modello:
Type:
Typ:

Kita HR 10/HR 10 3Phase/HR 12 /HR 12 3Phase/HR 14/HR 14 3Phase/HR14 Cold 3Phase / S / S 3Phase / S plus / S plus 3Phase / Si / Si 3Phase / Si Cold / Si Cold 3Phase / Si Plus / Si Plus 3Phase / Si Plus Cold / Si Plus Cold 3Phase / Mi / Mi 3Phase / Mi Cold / Mi Cold 3Phase / Mi Plus / Mi Plus 3Phase / Mi Plus Cold / L33 / L42 / L66 / L Cold / Li Plus / Air / Air Cold / Air Cold + Booster / Air Plus

Direttive UE
EU Directives
EU-Anforderungen

Direttiva attrezzature a pressione (PED) 2014/68/UE (PED);
Direttiva Macchine (MD) 2006/42/CE;
Direttiva Bassa Tensione (LVD) 2014/35/UE;
Direttiva Compatibilità Elettromagnetica (EMC) 2014/30/UE.

Norme applicate
Applied standards
Angewandte Norm

EN 55014-1:2006 +A1:2009;
EN55014-2:1997+A1:2001+A2:2008;
EN 61000-3-2:2006+A1, A2:2009;
EN 61000-4-2:2008;
EN 61000-4-4:2008;
EN 61000-4-5:2008.

Procedura di valutazione della conformità PED
PED Conformity assessment procedure
PED Konformitätsbewertungsverfahren

Categoria I, Modulo A – Controllo interno della produzione
Category I, Module A – Technical documentation and internal production control
Kategorie I, Modul A – Interne Fertigungskontrolle

La presente dichiarazione è rilasciata sotto la responsabilità esclusiva del fabbricante.
This declaration of conformity is issued under the sole responsibility of the manufacturer.
Die alleinige Verantwortung für die Ausstellung dieser Konformitätserklärung trägt der Hersteller.

Firmato a nome e per conto del fabbricante
Signed in the name and on behalf of the manufacturer
Unterzeichnet für und im Namen des Herstellers

Rubano (PD), 26/05/2022

Ing. Gianluca Masiero

(Technical Director / *Direttore Tecnico*)



A series of horizontal dashed lines for writing, spanning the width of the page.



Templari srl

RUBANO
via Pitagora, 20A
35030 Rubano (PD)
Italy

ABANO TERME
via C. Battisti, 169
35031 Abano Terme (PD)
Italy

Tel. +39 049 8597400
info@templari.com

www.templari.com



How to connect
K-touch display to
the heat pump



Video guide
K-Touch

